

KINETROL

Rotary Actuators

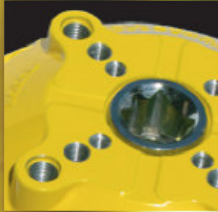

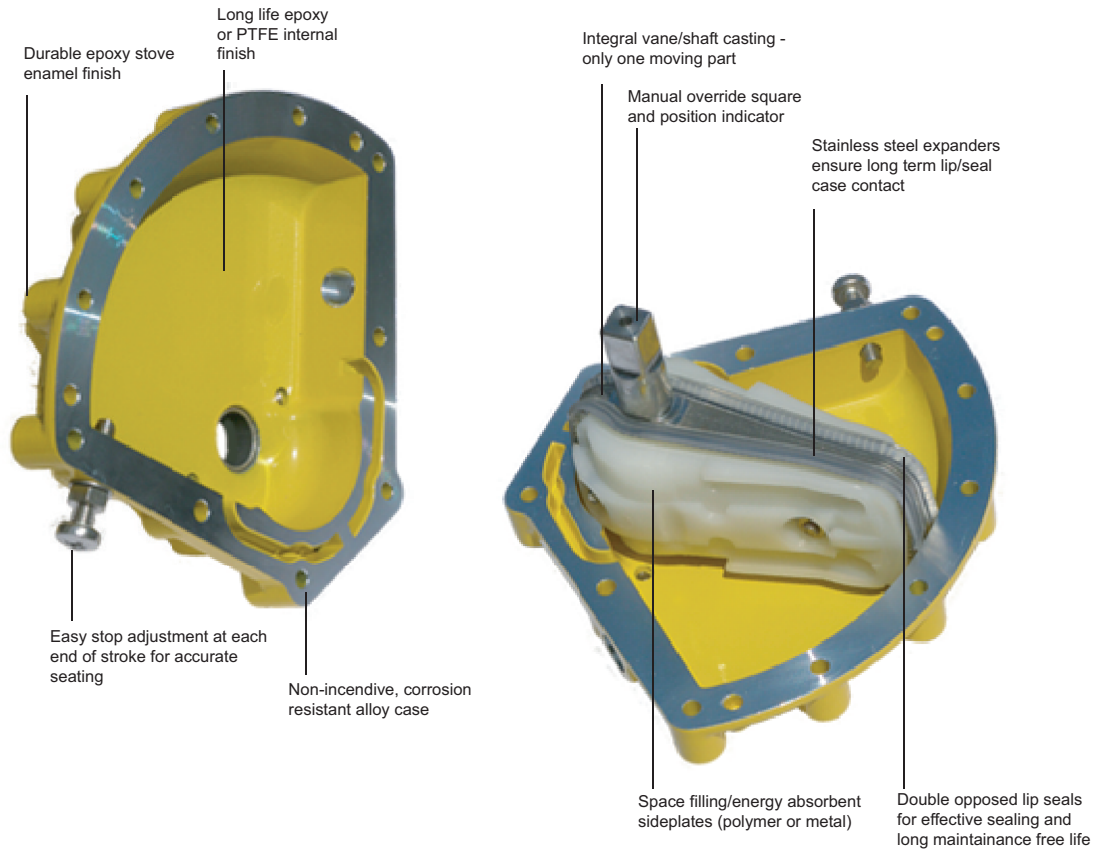

■ **Single moving part**

Simplest and most reliable mechanism for quarter-turn rotary actuation.

■ **Close couple control modules**

Fail-safe spring returns, limit switches, positioners and solenoid valves all close couple to the actuators.

■ **No cranks or gearing**

No power loss or backlash - allows accurate positioning.

■ **Durable corrosion resistant finish**

■ **Long maintenance-free life**

Up to 4 million operations guaranteed.

■ **Compact - space saving - efficient**

Best torque/size package available, fast operating speeds, best air consumption, proven design.

■ **Hundreds of thousands of units**

in trouble free service all over the world.

■ **Choice of male or female output drive square - easy to interface to application**

■ **Unique serial number for identification and traceability**

Applications

Operation or positioning of ball, butterfly and plug valves, ventilation dampers and automatic doors. Uses also include movement and positioning of components during manufacture - in fact anything that needs to be turned through 90° or less, automatically or by remote control.

For ordering codes see page 53
For catalogue index see page 54



Certificate No. FM22163

Kinetrol's rigorous quality program is approved to ISO 9001:2000 and AS/EN 9100 ensuring that each unit is manufactured to the highest standards.

The policy of KINETROL is one of continuous improvement. We reserve the right to alter the product as described and illustrated without notice.

Kinetrol modular concept easily provides the control assembly needed

1. Visual Indicator

Gives visual indication of valve position as standard except models OMO, 01, 08, 16, 18, 20 and 30.

2. Clear Cone Monitor

Gives 360° and overhead position indication. Available on actuator models 03, 05, 07, 09, 10, 12 and 14 limit switch boxes AP positioners, EL positioners and EHD models (details page 6).

3. I/P Controller

4-20mA electrical signal controls main air supply to pneumatic positioner as alternative to air signal control (details page 19).

4. AP Positioner

3-15psi (0.2-1 bar) air signal controls main air supply to turn, stop or hold the actuator vane in proportional response to that air signal. Limit switch and angle retransmit options available (details pages 17/18).

5. EL Electropneumatic Positioner

A single unit gives smooth accurate control in response to a 4-20mA signal. Limit switch and angle retransmit options in same housing (details pages 15/16).

6. P3 3-Stop Positioner

Provides two endstop positions and a mid-range setpoint anywhere within the 90° span. Easy setpoint adjustment and integral position feedback options (details page 13/14).

7. Universal Limit Switch Box

Weather tight unit with up to 4 switches for remote position indication or control use. Optional switches for flame proof/explosion proof needs and high visibility Clear Cone monitor (details pages 7/8).

8. Explosion Proof Limit Switch Box

Provides the same basic options as the Universal Limit Switch Box but in flame proof enclosure with ATEX, FM and IEC approvals (details page 11/12).

9. Solenoid

Optional integral pneumatic solenoid valve for actuators. Various electrical, environmental and explosion proof requirements covered (details page 6).

10. Actuator

15 sizes covering torque range 0.5 Nm (5 lbf in) to 19140 Nm (168,000 lbf in). Operating air pressure range 1.4 bar (20 psi) to 7 bar (100 psi). Adjustable stops standard. Restricted travel stops and DIN/ISO versions available (details pages 25 to 39).

11. 180° Converter

Compact units give constant torque output through up to 200° travel (details pages 23/24).

12. Fail-Safe Spring Return Units

Clock type spring return gives reliable fail-safe operation with high torque output throughout spring stroke, yet has easy adjustment to suit application (details pages 3-5).

13. ISO Adaptor

The patented ISO adaptor provides easy conversion from a Kinetrol male drive to an ISO flange interface for ultimate mounting flexibility (details page 20).

14. Gearbox

Geared manual override on all models from 05 to 16 inclusive, except 08 (details page 40).

15. Mounting Bracket

A comprehensive range of brackets provides for most ball, plug and butterfly valves (details page 43).

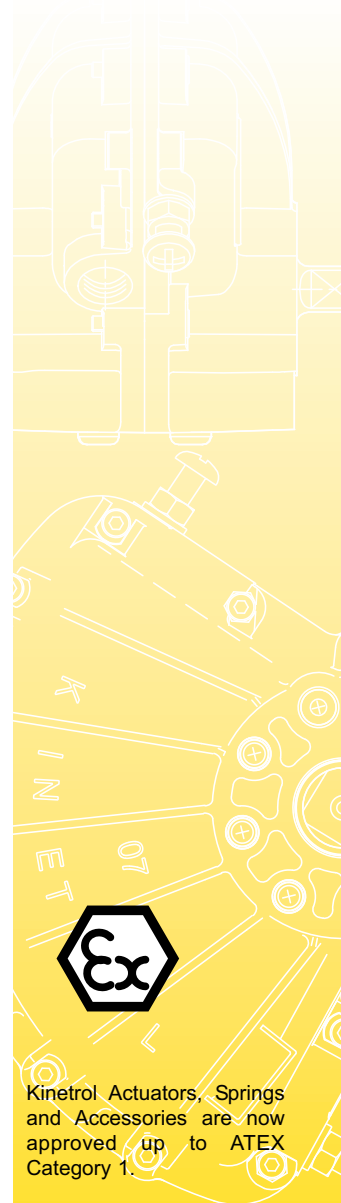
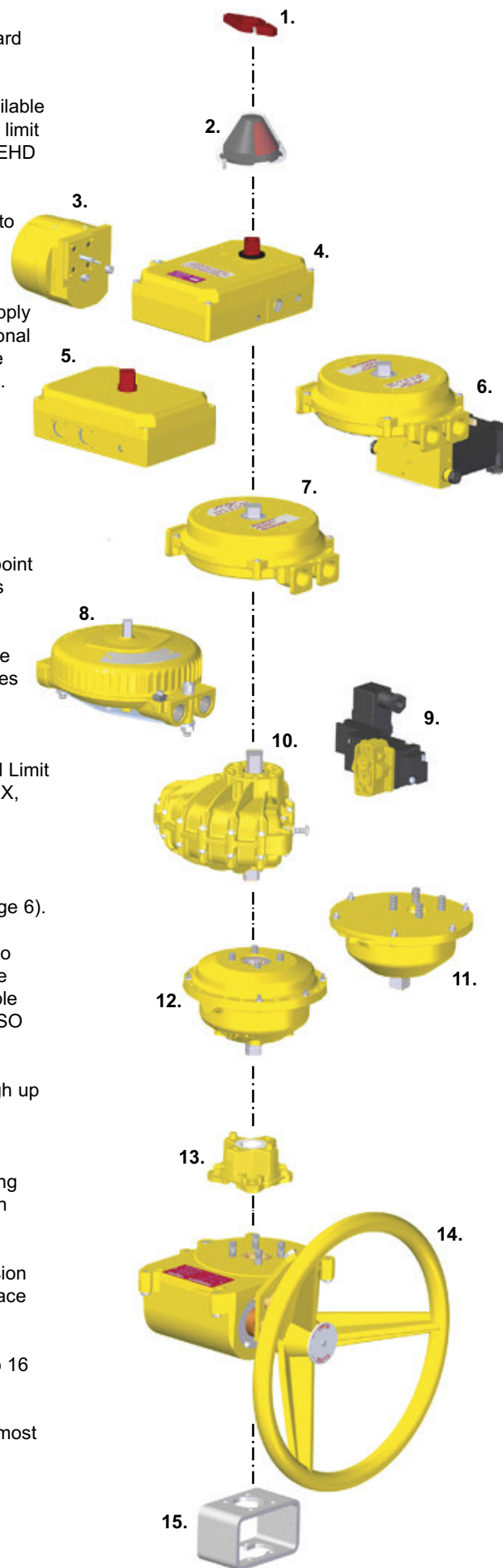

Kinetrol Actuators, Springs and Accessories are now approved up to ATEX Category 1.

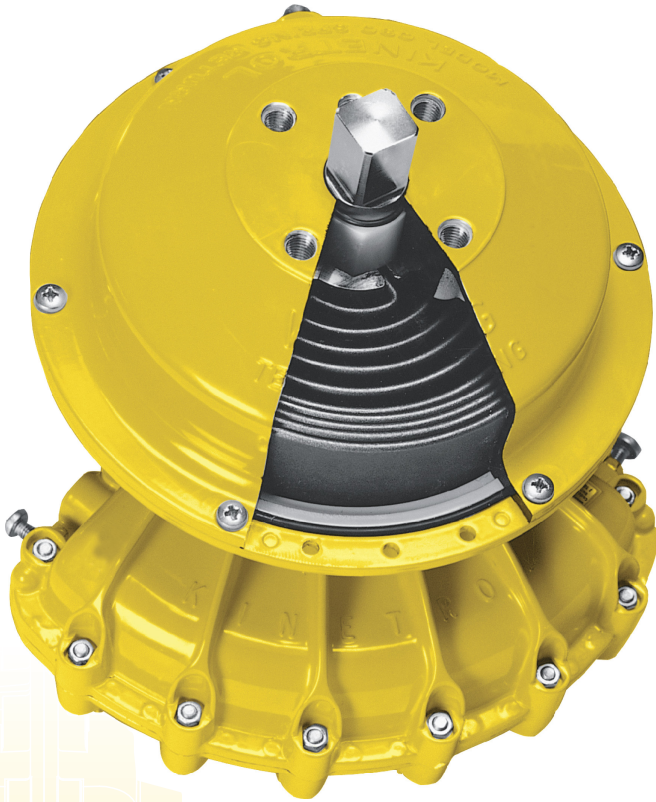

Spring housing cut away

- **Lowest Torque Loss**
 Typically 20% through 90° yields extra torque through spring stroke - enables the selection of smaller actuators (see diagram)
- **Reliable low stress range clock type spring**
- **Separate housing for modular assembly easily retrofitted**
- **Sealed, non-breathing housing**
 Protects spring in corrosive environments
- **Adjustable pretension for 'balanced' air and spring stroke torques**
 Various combinations available for balanced / optimised torques at various air pressures
- **Keeper plates available to ensure safe handling of pretensioned springs**
- **Available with ISO/DIN female drive and mounting for models 03-20**
 (except model 08)
- **Springs guaranteed against failure for lifetime of actuator**
- **ATEX Category 1 approved for many models**
 Category 2 for other models

The diagram shows the torque requirement of a typical ball valve under normal conditions. The typical torque output characteristics of Kinetrol and Rack and Pinion actuators, both sized to overcome the valve's breakout torque, are also illustrated. The diagram demonstrates that the Kinetrol actuator will exceed the torque requirement of the valve throughout the entire stroke whilst the rack and pinion unit will fail to reseat the valve.

The higher torque losses associated with the rack and pinion actuators (torque loss can be as high as 70%) dictate the selection of larger units to ensure complete reseating.

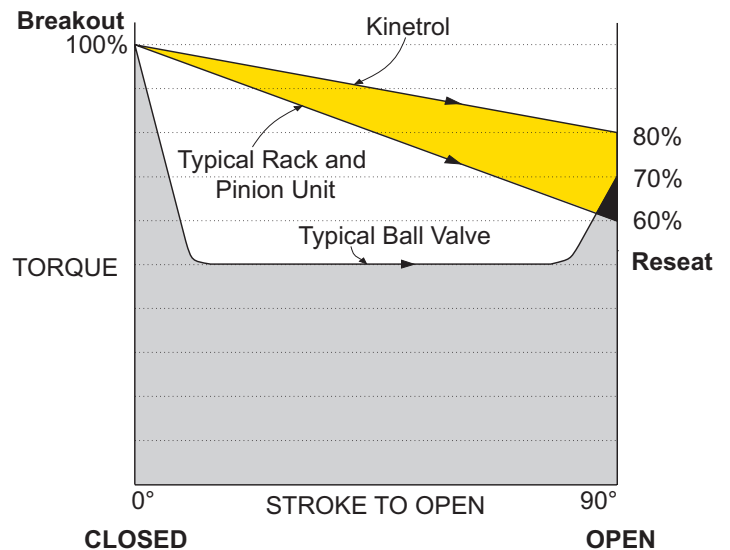

**KINETROL
SPRINGS**
Lifetime Guarantee

ATEX
TO CATEGORY 1
APPROVED

Direction of Spring Action

Spring units are available for either clockwise or counter clockwise spring action. Spring positioning, as standard, is between the actuator and application. With spring units alone, direction is determined by looking at the unit from the end which interfaces with the actuator.

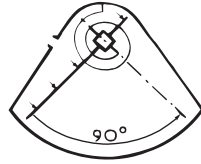

Suffix - 020 = clockwise
Suffix - 030 = counter clockwise

The direction of actuator/spring assemblies are determined by looking at whole assembly from the non-output end.

Asymmetrical Torque Applications

If high torque is required in one direction and lower torque in the other direction this can be set up easily by changing spring pretension to be higher or lower as required. Air stroke torque will always be double-acting torque (at air pressures available) less spring pretension torque.

Low Air Pressure Applications

If air pressure available for actuator operation is less than 50psi (3.5 bar) 'balanced' torque output on air and spring strokes is still possible by using a spring return unit from a smaller actuator size. Listed below are factory assembled options of this kind.

Replace the '**' used in ordering codes below with a '2' (clockwise) or '3' (counter clockwise) depending on direction of spring action required.

See pages 51 & 52 for full torque details and pages 45 & 46 for dimensions of all models, except where models marked with "+", are only available with spring above actuator (see page 4 of TD121).

Ordering Code	Description
03-1*0-5600	03 actuator with one 02 spring unit +
07-1*0-4000	07 actuator with one 05 spring unit
08-1*0-4100	08 actuator with one 07 spring unit +
09-1*0-4200	09 actuator with one 07 spring unit +
10-1*0-5800	10 actuator with one 09 spring unit +
12-1*0-4300	12 actuator with one 09 spring unit +
12-1*0-4400	12 actuator with two 09 spring units +
14-1*0-4900	14 actuator with two 12 spring units
14-1*0-5000	14 actuator with one 12 spring unit
16-1*0-6000	16 actuator with one 14 spring unit and one 12 spring unit +
16-1*0-6100	16 actuator with one 14 spring unit
18-1*0-7000	18 actuator with one 16 spring unit
20-1*0-7200	20 actuator with two 16 spring units
20-1*0-7300	20 actuator with three 16 spring units
30-1*0-7600	30 actuator with three 16 spring units
30-1*0-7700	30 actuator with four 16 spring units
30-1*0-7800	30 actuator with five 16 spring units

Pretension Setting

Factory assembled actuator/spring return assemblies have the spring pretension set for 'balanced' torque output when the actuator is operated by air at 80psi (5.5bar).

Factory assemblies can be preset for different air pressures below 80psi (5.5 bar) on request.

Spring return units supplied separate from actuators are also pretensioned for 80psi (5.5 bar) air operation unless otherwise stated.

Keeper Plates

These are provided on all pretensioned spring return units supplied separate from actuators. They are also available as spare parts. Refer to TD121 for part numbers.

A keeper plate must always be used to restrain spring tension whenever a spring unit case is removed from the actuator.

Materials Specifications

Spring Casing	Models 01-10 pressure die-cast in ZL 16 zinc alloy. Models 12, 14, 16, 18, 20 & 30 aluminium alloy.
Finish	Epoxy stove enamel.
Spring	Clock type spring steel.
Square	Steel, zinc plated.
Mount Holes (output end)	Same as matching actuator except model 01, low pressure combinations & ISO drive versions. See page 45/46 & TD121 page 4.

KINETROL SPRINGS
Lifetime Guarantee





- Simple, elegant direct-mount interface for most valves
- Multiple ISO mounting flange hole drillings for each model
- Large ISO/DIN compatible 'star' drive for most models
- Leak tell-tale/relief slots in mounting face
- Female serrated insert drive options available for maximum direct mount flexibility on some models
- Keeper plates available to ensure safe handling
- Same reliable, long-life, fully sealed spring unit as on male-drive units
- Allows accessories to be added to top of actuator (e.g positioner)

Torques are identical to standard and low pressure spring torques given on pages 51 & 52.

Directions of spring action are as described on page 4. Female drive spring units are designed to be mounted between the actuator and the application. Consequently, a female spring designated 'clockwise' as a separate module will, when mounted to an actuator, result in an 'anti-clockwise' assembly. Female drive springs are not designed to interface directly with modular switch boxes, positioners etc.

ISO/DIN 'Star' Drives

Female star (double square) drive spring fail-safe units are available for models 03 to 20, except for 08.

Star drive units are specified by adding a 'F' to the DIN/ISO code:

e.g. for a standard model 07 actuator with a female star drive, a regular 074-120 code becomes 073F120.

See TD121 for full dimensions.

Serrated Drives

Female serrated drive spring fail-safe units are available for models 05, 07 & 09 to give maximum mounting flexibility. Features include:

- Can accommodate large diameter valve stems
- Deep hole in shaft for long valve stems
- Precision stainless steel inserts
- Common internal drive shapes available
- Same spring can be used with different valve type/sizes
- 48 teeth allow many different orientations

Serrated drive units are specified by adding an 'S' to the ISO/DIN code:

e.g. for a standard model 07 actuator with a serrated female drive, a regular 074-120 code becomes 073S120.

See TD141 for full dimensions of the serrated drive springs and associated couplings.

A range of blank and internally profiled serrated stainless steel couplings are available (see TD141 for codes).

Coding of Alternative Flange Drillings

Some female spring fail-safe star and serrated drive models are available with alternative ISO mounting hole patterns (see TD121 and TD141). The digits '8' and '9' are used to designate clockwise and anti-clockwise versions respectively:

e.g. clockwise code 053F180 specifies the F04 flange alternative of the 053F120 specifies F03/05/07 version.

**KINETROL
SPRINGS**

Lifetime Guarantee

ATEX
CATEGORY 1
APPROVED



Clear Cone Monitor

The optional Clear Cone provides all round high visibility position monitoring on all limit switch boxes except code -003 type, 02/03 and positioner models. A red/green colour coded monitor is sealed inside a robust, clear polycarbonate cover.

The monitor is also available directly mounted onto actuator models 03, 05, 07, 09 and 10, all EHD units and 12 & 14 using adaptor plate.

For highly corrosive environments special cover materials are available - contact Kinetrol for details.

Conductive ATEX approved versions are also available - contact Kinetrol for details.

For dimensions see pages 47, 48 & 49.



Solenoid Valves

As an option KINETROL actuator sizes 03 to 14 can be supplied with integral solenoid valves with NAMUR interface. Air is ported through the actuator body via an adaptor so no external tubing is necessary.

Standard optional solenoid valves can be converted to 5 or 3 port versions by changing valve body plate supplied with the valve.

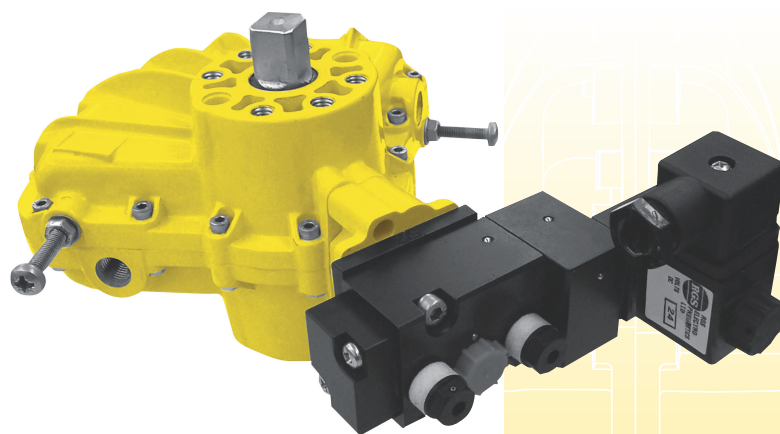

Specification

Coil voltages	AC: 50/60Hz 110v AC, 240v AC and 24v DC For other voltages contact Kinetrol
Electrical connection	DIN 43650 plug with Pg9 cable gland (6-8mm dia) as standard
Manual Override	Extra to order
Exhaust silencers / flow regulators	Extra to order
Hazardous areas	Certified solenoids are available as extras to order
Environmental Protection	To IP65 as standard
Minimum air supply	2 bar

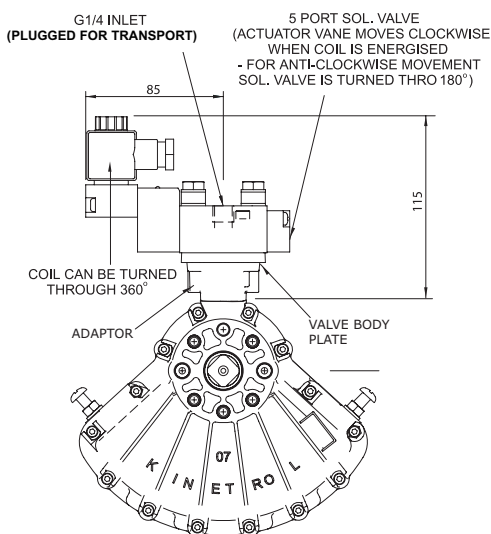

Single solenoid, 3 or 5 port, interchangeable for double acting or spring return, NAMUR interface. Most brands of NAMUR interface solenoid valve can be supplied to special order.



Universal Limit Switch Box



Offers a wide range of signalling options in a zinc alloy fully enclosed corrosion resistant case available for direct mounting onto Kinetrol rotary actuators, or discrete mounting via an industry standard VDI/VDE interface onto any make of rotary actuator. Easy to wire and set up with real industrial quality robustness. Internally fitted options include AS Interface digital communication and a 4-20mA 2-wire modulating angle retransmit circuit.

The range of switch and terminal arrangements includes 2 or 4 switches, extra connections allowing single point termination of wiring for limit switches and solenoid valves, ATEX approved Exed (Category 2) explosion proof and Exia intrinsically safe packages (Category 1). Integral sealed Clear Cone Monitor and red/green LED indicator options also give excellent external visual indication of position.

See KF487 for full details.

Specification

Casing

Precision diecast zinc alloy

Finish

Epoxy stove enamel

Seals

Nitrile rubber 'O' ring seals

Weight

1.4 kg

Cable entry options

2 or 4 entries

M20 x 1.5 Conduit thread

1/2 NPS Conduit thread

4 Way plug DIN 43650A (fits any of conduit thread)

4 Way M12 Connector (M20 Conduit thread only)

Temperature Range

Standard -20°C to 80°C

High Temp Seals up to 100°C

Dimensions

See page 49

- All units sealed to IP65/NEMA 4X IP67 options available.
- Robust corrosion resistant epoxy painted diecast zinc alloy box
- Easy and accurate setting of switch position
- Available for direct mounting to Kinetrol models 03 to 14, for minimum height
- Quick access - No special tools required
- Discrete VDI/VDE (NAMUR) interface option for use with industry standard actuators
- Two or four cable entries as standard to allow back wiring of solenoid valves
- Many switch options available for general and hazardous areas
- AS Interface bus circuit option inside box reads up to 4 switch inputs, drives up to 2 solenoids powered by bus only (see pages 9 & 10)
- Optional Clear Cone monitor available
- Integral LED indicator lamps and angle retransmit circuit options are available
- Compact SPST version of type 004 available for model 02 actuator

LOAD RATINGS FOR STANDARD MICROSWITCHES (type 004)

Voltage	Resistive Load
125 V AC	15A
250 V AC	15A
up to 12 V DC	15A
up to 24 V DC	10A
up to 48 V DC	3A
up to 250 V DC	0.25A

MULTIPLICATION FACTORS FOR NON-RESISTIVE LOADS

Steady state tungsten lamp load	- x 0.1
Steady state inductive load	- x 0.2
Peak inductive load	- x 1.0



Ordering Codes

Switch Type 001

2 intrinsically safe 2 wire inductive proximity sensors for hazardous areas (ATEX CAT 1), -20° to 80°C, normally open.

Switch Type 002

2 pneumatic switches with inlet adaptors for 4mm i/d tube (ATEX CAT 2).

Switch Type 003

Certificated unit to EEx e II T6 for hazardous areas to Zone 1 (ATEX CAT 2) 2 x 3 wire switches for SPDT.

Switch Type 004

With 2 x 3 wire microswitches for SPDT.

Switch Type 005

2 x 2 wire proximity sensors 20-260 volts AC, normally open.

Switch Type 006

2 x 2 wire proximity sensors 5-60 volts DC, normally open, with LED switch status indicators.

Switch Type 007

With 4 microswitches wired for DPDT.

Switch Type 008

With 2 intrinsically safe 2 wire slotted proximity sensors for hazardous areas (ATEX CAT 2), normally open.

Switch Type 009

2 x 3 wire gold plated contacts intrinsically safe microswitches for SPDT (ATEX CAT 1).

Switch Type E

2 x 2 wire proximity sensors 20-140 volts AC /10-140 volts DC.

Option B - E

AS interface options are available with both the two and four entry Kinetrol Universal limit switch boxes. Options B to E allow for different extended addressing options. For more information on the Kinetrol AS Interface card see page 9.

Option P

Two or four way Universal limit switch box fitted with potentiometer (20K ohms conductive plastic type).

Option R

Two or four entry Universal limit switch fitted with angle retransmit, loop powered two wire circuit passes 4-20mA current, proportional to 0-90° position of actuator.

Option U

Two or four entry Universal limit switch box without AS interface card.

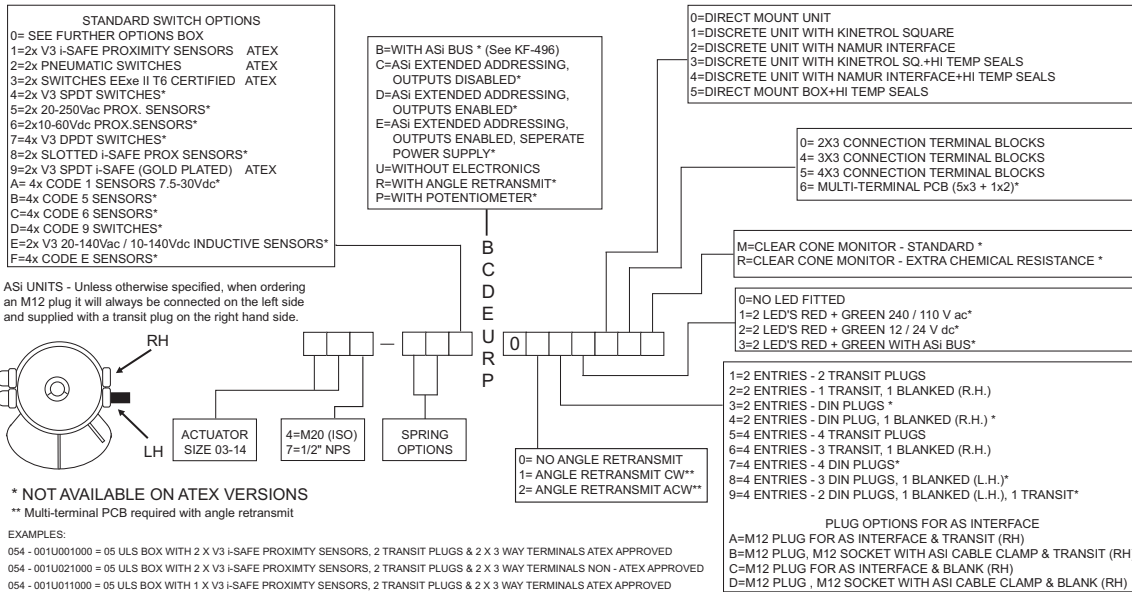

* NOT AVAILABLE ON ATEX VERSIONS
 ** Multi-terminal PCB required with angle retransmit

Further switch options are available upon request - contact Kinetrol for details

Universal Limit Switch Box



For more information see KF-487





AS Interface Bus

The AS interface card allows easy digital serial communication for your sensors and actuators, allowing your actuators to be controlled and monitored when they are in the field, via a single 2 wire cable.

Actuator Sensor interface devices are used to make up control systems based on a two-wire communication cable known as a bus, and can be controlled or monitored by means of a digital signal sent via the bus to and from a "master" device (which can be a computer or a PLC).

The slave devices will always function in response to commands sent by the master device, either to actuate or to return a message reporting the value of a sensed variable, or both. The AS Interface specification allows 31 or fewer slave devices to be powered by a DC voltage fed into the same two wire cable used as the communication bus, with allowed power consumption adequate to drive the slave plus a standard pneumatic solenoid valve.

An AS Interface bus can be used as the final field link in a more complex hierarchy of devices making up a large plant-wide control system. Actuators and sensors must often be installed in unprotected environments where conditions can be demanding; the AS Interface bus can be used as the link between these field devices and the "indoor" equipment making up the upper part of the control system.

The AS Interface bus is designed for on/off control and monitoring and is a good choice when a simple, economical, reliable and robust solution is required for controlling and monitoring a series of actuators and sensors in a process control or machine application.

The Kinetrol AS Interface Card

The Kinetrol Actuator Sensor Interface card is fitted inside the Kinetrol Universal Limit Switch box, thus combining the industrial quality robustness of the box with the advantages of digital serial communication.

The AS interface bus cable can be routed in through the conduit entries and connected at internal terminal blocks, alternatively an M12 connector plug facing outwards from conduit entry can be supplied to allow quick connection from M12 sockets or with clip on adaptations for ribbon type yellow AS interface cables.

AS Interface Card Features

- **AS interface 2.1 compatibility**
- **Up to 31 units with solenoid valve on-off control, powered and controlled via one two core cable**
- **Up to 62 units** (using extended addressing)
- **All metal robust industrial-quality limit switch box, direct mounted on a Kinetrol actuator**
- **2 on/off outputs per unit**
- **4 on/off inputs per unit**
- **Reads mechanical switches or inductive sensors**
- **Retrofittable to standard Kinetrol Universal Limit Switch Box**
- **Can also be supplied in an explosion proof housing and with European, North American and World approvals**
- **LED external indicator option**
- **Up to 31 24V 2.5W solenoid valves can be connected to bus with no separate power supply**
- **M12 connector plug option available for instant bus connection**
- **Cable clamping connector block for yellow ribbon-type AS interface cable available with M12 socket to fit onto plug option**
- **Output short circuit protection built in**



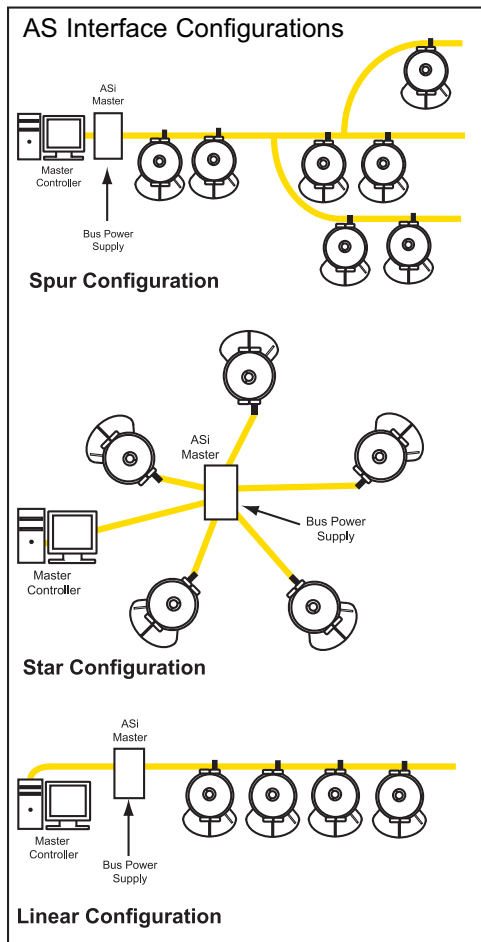

AS Interface 2.1 Specification

- **Master - Slave protocol**
- **Up to 31 Slaves per master**
- **Each slave has its own unique address (set by user)**
- **All slaves can be scanned every 5 milliseconds**
- **Baud Rate - 197 Kbits/second**
- **Slaves may be added anywhere in the bus**
- **Slaves may be parallel connected on the bus, using star or spur configurations**
- **Up to 124 inputs per bus**
- **Up to 124 outputs per bus, 62 using the Kinetrol device**
- **26.5 to 31.5 Vdc, 8 A max power supply**
- **100 m (325ft) maximum cable length (repeaters may extend network distance)**
- **Untwisted, unshielded, 2-wire (1.5mm²) cable can be used**

AS Interface Extended Addressing

Kinetrol's AS Interface circuit is a slave device to allow 32 devices (usually 31 slaves plus an AS Interface master device) to be powered and controlled via a 2-wire bus cable, with full capability to energise one solenoid on every unit all at the same time. This is the standard (Option code B).

The AS Interface 2.1 specification also allows for an extended address option, whereby 62 addresses can be connected and powered via one bus cable. The specified limits on device capacitance however, mean that if the full extended-address compliment of slaves all had standard solenoid valves connected, the bus limit would be exceeded.

Kinetrol offer these options to allow use of extended addressing:

1. (Option Code C)

AS Interface circuit with extended addressing enabled and outputs disabled, to read limit switch sensors only. If a solenoid is connected it will not function.

2. (Option Code D)

AS Interface circuit with extended addressing and outputs enabled, plus added isolating relay option fitted to outputs, to allow up to 31 solenoids to be energised simultaneously even from the bus, though up to 60 slave units may be connected to the bus. This requires the user's control system to include a pre-programmed limit on the maximum number of solenoids to be energised. If the system instructs too many units to switch on solenoids, they will obey, and the bus capacitance limit will be exceeded – thus this option must be at the user's risk with regard to this issue.

3. (Option Code E)

AS Interface circuit with extended addressing and outputs enabled, plus added relay options fitted to outputs to allow solenoid valves to be powered by a supply separate from the AS Interface bus. This option requires a separate 24V DC power supply to each actuator, and allows up to 60 slave units to energise their solenoids simultaneously.

To order the Kinetrol AS Interface card refer to codes for Universal Limit Switch Box or Explosion Proof Limit Switch Box on pages 8 and 12.

For more information
see KF-496



Explosion Proof Limit Switch Box



The Explosion Proof Limit Switch Box offers a wide range of signalling options in a compact corrosion resistant aluminium alloy housing available for close - mounting onto Kinetrol actuators or discrete mounting via a Kinetrol 05 square or industry standard VDI/VDE interface onto any make of rotary actuator. Easy to wire and set up with true industrial robustness.

Internally fitted options include AS interface digital communication and a 4-20mA, 2-wire, modulating angle retransmit circuit. The range of switches and terminal arrangements includes 2 or 4 switches and extra connections - allowing single point termination of wiring for limit switches and solenoid valves. This product is available to mount on Kinetrol models 03 - 30.

- Wide range of worldwide explosion proof approvals including IECEX, ATEX & FM (for USA & Canada) - all in one device
- All units protected to IP66 / NEMA 4X / TYPE 4X
- Attractive, functional and part-spherical profile. Robust corrosion resistant, anodised & epoxy painted diecast aluminium alloy housing
- Close - mount to Kinetrol actuator models 03-14 for low profile
- Discrete Kinetrol 05 square drive insert for use with Kinetrol actuator models 16 -30
- Discrete NAMUR drive for use with VDI/VDE 3845 drive actuators
- 2 or 4 cable entries available to allow back wiring of solenoid valves
- Up to 4 switches available for SPDT, DPDT or multiple circuit operation
- Easy and accurate setting of switching position
- Optional antistatic Clear Cone Monitor available
- Integral angle retransmit circuit options are available
- Integral AS interface bus circuit option reads up to 4 switch inputs and drives up to 2 bus powered solenoids
- -40° C to +80° C ambient operating temperatures (dependent on switch options)
- 3-stop positioner options available (refer to pages 13/14 for details)



Switching Operation Conditions

Switch Code	Voltage		Current	Temperature Range
	AC	DC		
1/A	-	8	6mA	-20 to +80°C
4/7	250	48	2.4A AC/1.8A DC	-40 to +80°C
5/B	250	300	100mA	-20 to +70°C
6/C	-	60	100mA	-20 to +80°C
9/D	-	30	100mA	-40 to +80°C
E/F	140	140	200mA	-20 to +80°C

Specification

NORTH AMERICAN APPROVAL

Type of protection, Explosion Proof
 US: Class I, Division 1, Gas groups A, B,C,D. Class II, Division 1, Dust groups E,F,G. T5 NEMA 4X
 CANADA: Class I, Division 1, Gas groups B,C,D. Class II, Division 1, Dust groups E,F,G. T5 TYPE 4X.

EUROPE/GLOBAL - ATEX / IECEx APPROVAL

Protection Flame Proof 'd'
 Group II C/A21, Category 2, Gas & Dust, T5, IP66

Labels

IECEX & ATEX - Approval type E

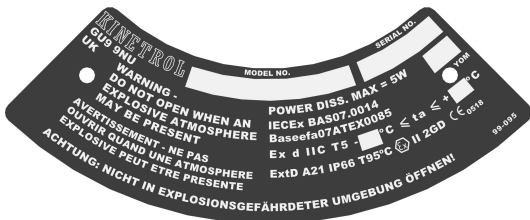

FMC/U, IECEx & ATEX - Approval type F & P

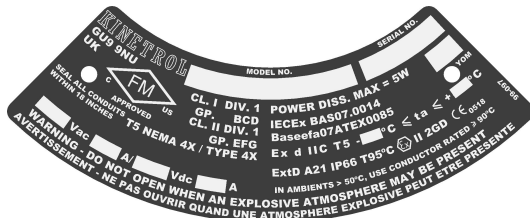

Casing Precision diecast LM24 alloy, anodised & epoxy stove enamel.

Coupling Zinc plated steel.

Seals Fluoropolymer dynamic seals. Nitrile butyl rubber static seals.

Weight 1.5 Kg

Cable Entry Options M20 x 1.5 or 1/2" 14 NPT conduit entry threads.

Dimensions See page 49

Ordering Codes

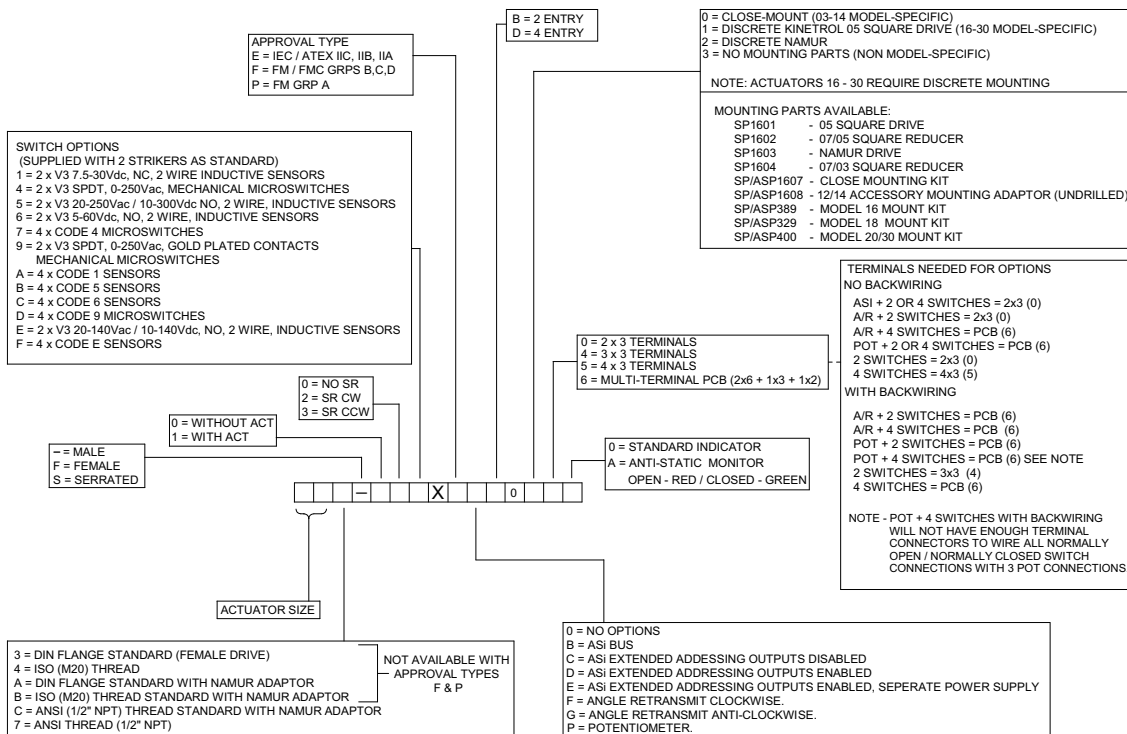

For more information see KF-619



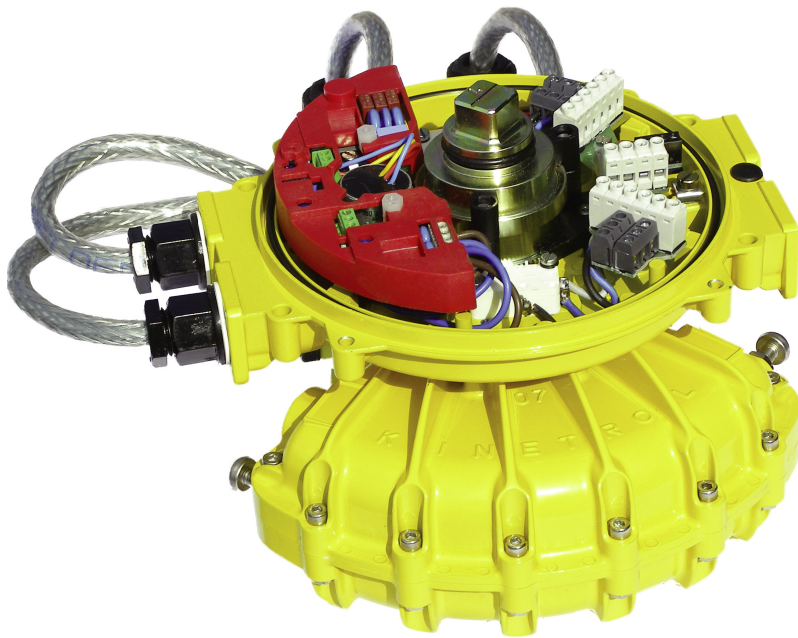

The P3 3-stop positioner consists of an electronic positioning circuit mounted in a robust all-metal enclosure, which controls a ¼-turn rotary pneumatic actuator via standard on-off solenoid valves direct-mounted on the actuator's own interface.

The P3 circuit is designed so that its assembly can be mounted inside a standard Kinetrol limit switch box (either ULS-type, or explosion proof XLS-type), using only two screws. The P3 assembly is complete with feedback potentiometer and anti-backlash gear drive, which engages with gear teeth on the limit switch coupling to read the actuator's position. The limit switch coupling complete with gear teeth needs to replace the standard coupling if a standard box is being retrofitted with a P3.

The positioner circuit is powered by the mid-point input voltage. It functions by comparing the actual mid-point position (read by the feedback potentiometer) with the set position (set via an on-board preset, or a remote preset, or a remote 4-20mA signal). The positioner circuit uses its solid-state switched outputs to power solenoid valves which drive the actuator towards the position where the set position corresponds with the actual position. When it gets there, the solenoids are switched to hold that position.

The positioner circuit incorporates a unique power supply allowing it to be powered by any of 24vDC, 48vDC, 115vAC or 230vAC, 50/60 Hz, without the need for any change. The supply maintains full isolation of the low voltage control circuit from the power input line (up to 5Kv). Switching of the solenoid valve outputs is achieved through opto-isolated solid state switches which operate at all the above voltages – only the solenoid coils themselves need to be adapted specifically to the supply voltage. The use of solid state switching avoids any limitations on relay contact life.

Double acting models are available as fail-free (standard), fail-down (moves clockwise on loss of electrical power if air supply is still present) and fail-hold (holds position on loss of electrical and / or air supply) variants. Spring return models move in the direction of the spring on loss of electrical failure, but hold position on loss of air.

An external pressure switch (which cuts electrical power on loss of air pressure) should be fitted by the customer if spring function is required on loss of air and / or electrical power.

An optional angle retransmit (AR) circuit can be retrofitted by plugging it into the top of the positioner circuit and fixing with three screws. The AR circuit is a 2-wire loop-powered 4-20mA device, which reads the position of the positioner's feedback pot. It is fully functional whether or not the positioner circuit is powered, and the feedback signal is electronically isolated (ie. floating) relative to the low voltage positioner circuit (which in turn is electrically isolated from the power supply and solenoid connections).

Extra solid-state switches have been incorporated on the positioner board to allow supply to both solenoid valves via a single cable for movement to the upscale position when the positioner is in spring-return or fail-down mode, while still allowing the positioner to control the two valves independently for the mid position. If the mid-position input is energised, then these extra switches isolate the solenoids from the upscale/downscale inputs.

The three power input lines (for up, mid, down positions) are independently fused using plug-in miniature fuses on the positioner circuit board.

External connections are made via a multi-option connector board, which allows simultaneous connection of up to four changeover limit switches, three control supply inputs plus neutral/negative, and a single low-voltage signal. This connector board, like the positioner circuit assembly, mounts in either the standard ULS or XLS box using two screws.

If an angle retransmit circuit is fitted using the low voltage signal terminal, optional 4-20mA inputs or external setpoint pot wires can be connected either directly to the terminal block on the positioner circuit or, if only three or less limit switches are in use, relayed through an unused limit switch terminal on the connector board.

The limit switch box is fitted with a ground terminal which must be connected to a suitable external ground.

Solenoid valves are direct-mounted on adaptor blocks on the side of the actuator, and electrically connected via steel-armoured flying leads with DIN sockets on the solenoid end. At the positioner end, they connect to two 2-way terminal blocks on the circuit board. A range of solenoid valve options are available, determined by the function required, the supply voltage, and whether or not the unit requires hazardous area certification. Customer selection is via the order code.





Operation

The EL positioner uses a unique low power proportional servo valve to control the position of a quarter-turn actuator.

The microprocessor in the loop-powered 4-20mA position circuit reads the signal via one channel of a 12-bit A-D converter, reads the position voltage from the feedback potentiometer via the second channel of the A-D converter, and compares the two. If it detects a position which is different from that required by the signal, it changes the output to the servo valve in order to drive the actuator in the direction required to reach the correct position. As the actuator moves, the feedback potentiometer voltage changes and the microprocessor continually calculates the adjustments required for the servo valve in order to guide the actuator accurately into position. The microprocessor is programmed with a sophisticated but compact algorithm which allows this critical dynamic valve adjustment to be made correctly, which in turn gives optimal results with any actuator/load combination - slow or fast, low or high friction, low or high inertia. All can be optimised by tuning the PGAIN and DAMP push buttons via the positioner circuit push buttons.

The EL positioner controls airflow to an actuator and moves it to a position determined by a 4-20mA signal. It's features are:

- **Fast, smooth, and precise control from a digital circuit and proportional servo valve**
- **Simple time saving field set up**
Quick calibration via push buttons and LED feedback and easy reversal of rotation sense (clockwise/counter clockwise) without special tools or parts change.
- **Universal application**
The unit can be mounted in any orientation on to any quarter turn or linear application by connection via a NAMUR or Kinetrol square interface.
- **Loop powered**
No separate power needed, just 4-20mA signal plus air supply.
- **Integral options - easily retrofitted modules include:**
 - two wire 4-20mA isolated angle retransmit
 - mechanical or inductive position indicator switches (general or hazardous areas)
 - Clear Cone high visibility indicator
 - Threaded conduit entries or DIN plugs for external connection.
- **Intrinsically safe approved options**
- **Weatherproof, compact and robust metal housing**
- **Zero backlash coupling with easily adjustable switch strikers**
- **Vibration and shock resistant to 4G**
- **Built in gauge ports/external connections**

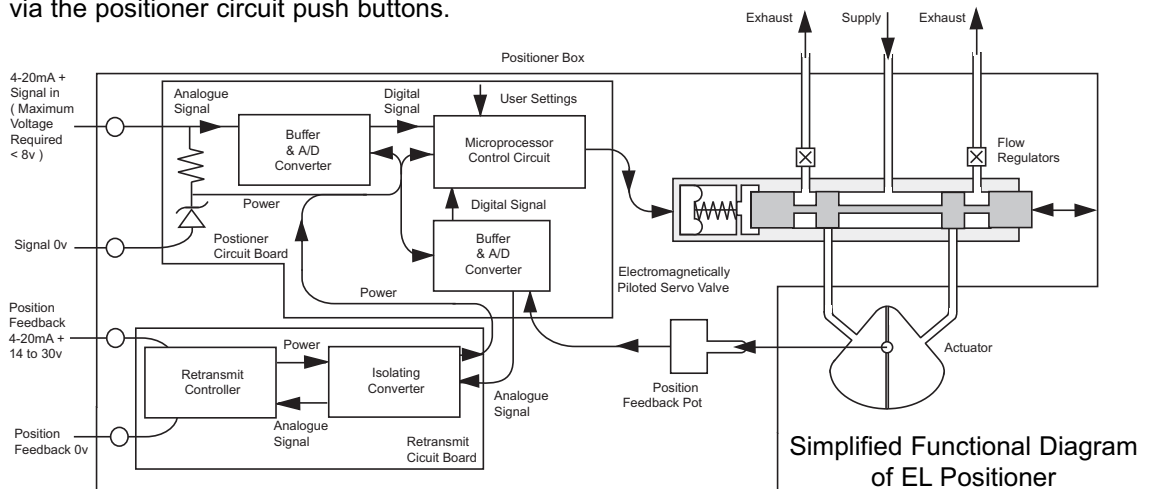

Application

This EL positioner can be directly mounted on special versions of Kinetrol models 05, 07, 08, 09, 10, 12 and 14 actuators, both double acting and spring return, giving an assembly with no external plumbing, wiring or mechanical connections and the best backlash free control. Mount kits are available for models 16, 18, 20 and 30 actuators.

Alternatively, discrete versions mount on any actuator via VDI/VDE 3845 NAMUR drive, or Kinetrol male square, with mounting bracket. Special adaptations for linear cylinders are also available - consult Kinetrol for details.

The EL Positioner ATEX approval includes the fitting of a special version of the popular Clear Cone high visibility monitor. The EL approval also now allows for the EL Positioner to be used in certain dust atmospheres. It is important to note that the approval of the EL Positioner for use in dust atmospheres is limited to non-conductive dusts having resistance higher than 1000 ohms-m.

Travel Times

Direct mount from EL positioner to actuator (zero load)

Model	05	07	09	10	12	14
Deg/Sec	129	65	33	22	15	7.5

Externally piped from EL positioner to actuator (zero load)

Model	07	09	10	12	14	16	18	20
Deg/Sec	76	38	28	18	8.6	4.1	2	1

Ordering Codes

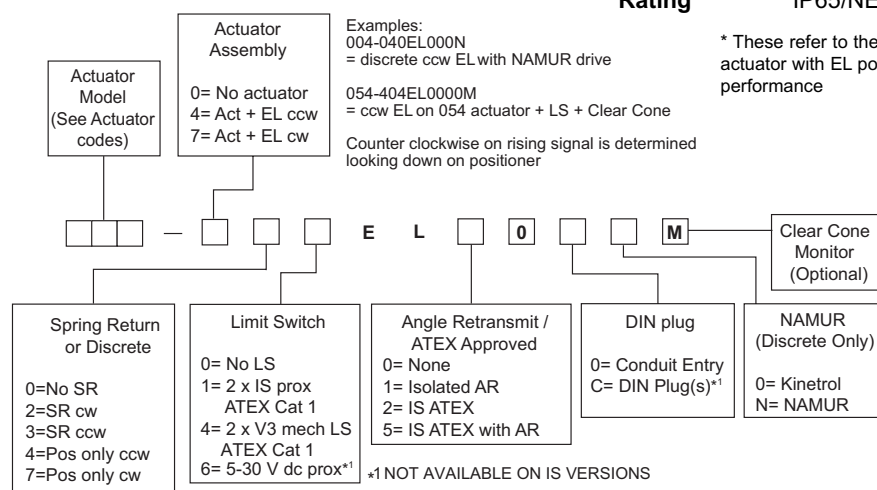

Specification

Air supply	instrument quality (dry, clean, oil free Class 6.4.4 ISO8573.2001), 3.5 to 7 bar (50 psi to 100 psi). Consult Kinetrol for 5µm inlet air filter option
Signal	4-20mA, requiring max 8V to drive through positioner circuit (compatible with standard 24V dc source)
Control Response	0-90° positioning with one linear and 10 non-linear preselected characteristics as standard. Consult Kinetrol for the following versions: i) linearisation of butterfly valve characteristics ii) Pre-selected travel time extension option (with active feedback control of travel speed) iii) customised responses
Sensitivity	better than 0.1mA*
Hysteresis	better than 0.7% of span*
Repeatability	better than 0.7% of span*
Deviation from Linearity	less than 0.7% of span*
Flowrate	3.3 scfm/93 l/m @ 5.5 bar
Operating Temperature	-20° to +70°C (-4°F to 160°F)
Adjustments	low & high points (define range), proportional gain, velocity proportional setpoint advance (damping)
Weight	2.95 Kg/6.5 lb
Dimensions	see page 48
Materials	case and cover - zinc alloy spool and liner - stainless steel
Finish	epoxy stove enamel
Enclosure Rating	IP65/NEMA 4X

* These refer to the combination of Kinetrol actuator with EL positioner - not just the positioner performance

For more information see KF-372





Operation

The AP Positioner is designed to drive a rotary or linear actuator to a position set by a 3-15 psi (0.2 to 1.0 bar) signal and hold it there until the signal changes. When a signal pressure is applied to the diaphragm it moves the force balance lever clockwise against the tension of the feedback spring. This moves the spool valve, supplying air pressure to one side of the actuator while exhausting trapped air from the other side. The feedback shaft follows the movement of the actuator and turns the cam counter clockwise, pushing the cam follower and increasing the tension on the feedback spring until it balances the forces on the diaphragm and moves the spool valve to its hold position.

The input signal and desired position is determined by the cam profile. A cam giving 0-90° output movement linearly proportional to a 3-15 psi (0.2-1.0 bar) signal is standard, and almost any desired characteristic can be supplied to order; if it cannot be found in the list of existing options contact Kinetrol.

Schematic Functional Diagram

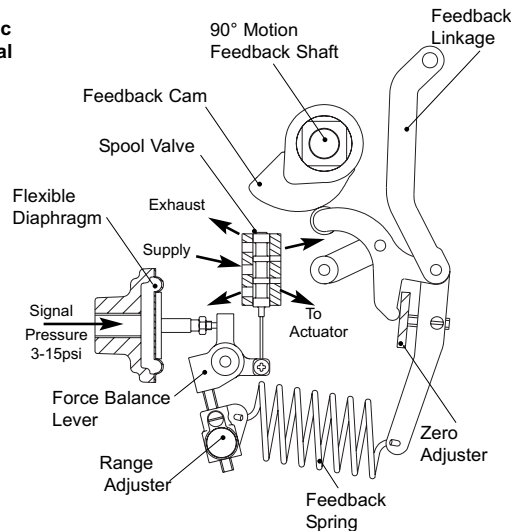

The AP positioner moves an actuator to a position set by a 3-15psi control signal and holds it there. Its features are:

- **Fast, smooth, accurate response**
- **Simple, all-mechanical function for unbeatable reliability**
- **Three flow options to optimise control on all actuator sizes**
- **Universal application**
The unit can be mounted in any orientation on to any quarter-turn or linear application
- **Easy set up**
Quick calibration and reversal of rotational sense (clockwise and anti-clockwise) without special tools or parts change
- **ATEX CAT 1 approved versions available**
- **Easily retrofitted integral module options include:**
 - Two wire 4-20mA angle retransmit (inside the same case)
 - Mechanical or inductive limit switches (general or hazardous areas)
 - 4-20mA I/P convertors (general or hazardous areas)
 - Clear Cone visual position indicator (general or hazardous areas)
 - DIN plug option for retransmit connection
 - Low (-40°C) and high (100°C) temperature versions available
 - Fail hold options available
 - Choice of mount options - see opposite
- **Weatherproof, compact and robust metal housing**
- **Vibration and shock resistant to 4G @ 50Hz**
- **Built in ports for signal air supply and gauge connections**



The AP positioner can be directly mounted on special versions of Kinetrol models 05, 07, 08, 09, 10, 12 and 14 actuators, both double acting and spring return, giving an assembly with no external plumbing, wiring or mechanical connections and the best in direct backlash free control. Mount kits are available for models 16, 18, 20 and 30.

Alternatively, discrete versions mount on any actuator using VDI/VDE 3845 NAMUR drive, or Kinetrol male square with mounting brackets. Neat adaptations for linear cylinders are also available - consult Kinetrol for details.

Specification

Air supply	instrument quality (dry, clean, oil free) 3.5 to 7 bar, (50 psi to 100 psi) standard. Consult Kinetrol for low pressure application
Signal	3-15psi (0.2-1.0 bar) standard Consult Kinetrol for split range, 6-30 psi etc.
Control Response	0-90° linear output standard. Consult Kinetrol for other characteristic cam options
Sensitivity	better than 0.7% of span*
Hysteresis	better than 0.7% of span*
Deviation from linearity	less than 1% of span*
Flowrates @ 5.5 bar	AP: 3.3 scfm (93nl/min) MP: 10.0 scfm (283nl/min) HP: 27.0 scfm (764nl/min)
Operating Temperature Range	-20° to 80°C Standard -20° to 100°C High Temp -40° to 50°C Low Temp

Weight	2.8 Kg/6.2 lb
Materials	<ul style="list-style-type: none"> • case and cover - zinc alloy • spool and liner - stainless steel • diaphragm: <ul style="list-style-type: none"> - reinforced polyurethane (standard) - fluorocarbon rubber (high temp) - silicone rubber (low temp) • feedback spring - steel
Dimensions	see page 47

Finish	epoxy stove enamel
Enclosure Rating	IP54
Output torque	same as double acting or spring return actuator. When controlling fast movement of inertia loads consult Kinetrol

* These refer to the combination of Kinetrol actuator with AP positioner - not just the positioner performance

Maximum vibration tolerance 4G, 50 Hz

I/P Converter options See Page 19

Travel Times

Maximum velocity (no load) at 80psi 5.5 bar

Model	05	07	09	10	12	12*
Deg/Sec	180	90	45	33	25	32

Model	14	14*	16*	18*	20*
Deg/Sec	10.6	13.8	22.5	11.3	5.6

*Externally piped

Cam Options

Giving typical control characteristics. Contact Kinetrol for details of other options.

Input Control				
Air Signal	Electrical Signal	Output Movement	Characteristic	Cam No
3-15 psi 0.2-1.0 bar	4-20mA	0-90°	Linear	5-1A
3-9psi 0.2-0.6 bar	4-12mA	0-90°	Linear	5-2A
6-12 psi 0.4-0.8 bar	8-16mA	0-90°	Linear	5-3A
9-15psi 0.6-1.0 bar	12-20mA	0-90°	Linear	5-4A
3-15 psi 0.2-1.0 bar	4-20mA	0-60°	Linear	5-5A
3-15 psi 0.2-1.0 bar	4-20mA	0-45°	Linear	5-6A
3-15 psi 0.2-1.0 bar	4-20mA	0-90°	Proportional Flow	5-7A
3-9 psi 0.2-0.6 bar	4-12mA	0-90°	Proportional Flow	5-8A
9-15 psi 0.6-1.0 bar	12-20mA	0-90°	Proportional Flow	5-22A
3-12 psi 0.2-0.8 bar	4-16mA	0-90°	Linear	5-13A
9-15 psi 0.6-1.0 bar	12-20mA	0-60°	Linear	5-14A

Ordering Codes

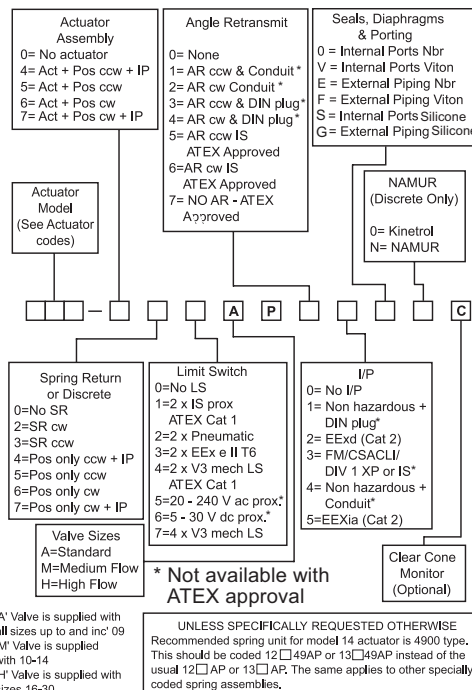

'A' Valve is supplied with all sizes up to and inc' 09
'M' Valve is supplied with 10-14
'H' Valve is supplied with sizes 16-30



For more information see KF-391





The optional Kinetrol I/P Controller is mounted in place of the standard diaphragm housing on the side of the positioner case. The positioner can still be mounted in any attitude and gives an angular output position which is proportional to the input current control signal between 4-20mA.

The 4-20mA signal is converted to an air pressure by a coil and magnet and flapper valve arrangement. This air pressure controls the positioner in the normal way.

Zero and range adjustment is done within the positioner in the same way as with a standard pneumatic positioner. No adjustment is necessary within the I/P Controller. The cover is removed only to connect the two wires - this is not necessary with the DIN plug option.

I/P Controller - Hazardous Area

Kinetrol offers various optional I/P converters which are explosion proof or intrinsically safe certified for use in ATEX Zones 1 & 2 or NEC and CSA CLASS I DIVISION 1. They are mounted directly onto Kinetrol AP positioners with integral air supply.

Certificated as follows

- | | |
|----------------------|---|
| ATEX (Cat 2) | Explosion proof EExd II T6
Intrinsically safe EEx ia II C
T4/T5/T6 |
| NEC & CSA | FM explosion proof
CLI/DIV1/GRP B C D
FM Intrinsically safe
CLI/DIV1/GRP A B C D E F G
CSA explosion proof CLI/
DIV1/GRP B C G |

Specification - Safe Area

Electrical Control Signal	4-20mA
Coil Impedance	20 ohms typical
Cable Entry	16mm conduit or gland (mini DIN plug, IP 65 with Pg9 cable gland, 6-8mm dia optional)
Air Supply	80 psi/5.5 bar nominal
Air Entry	G ¹ / ₈ (fitted with 6mm pipe dia. push in connector)
Weight	1.2Kg
Dimensions	see page 47
Linearity	1.5%*
Hysteresis	less than 1%*
Sensitivity/Deadband	less than 1%*
Supply Pressure Influence	0.2% per psi between 80 and 60 psi
Quiescent Air Consumption	3.5 l/min free air max
Working Temperature Range	-20°C to 80°C
	Instrument quality dry clean air obligatory (Class 6.4.4 ISO8573.2001)
	* These refer to the combination of Kinetrol actuator with I/P controller - not just the positioner performance

Specification - Hazardous Area

Electrical control Signal	4-20mA
Input Resistance	260 ohms at 20°C
Cable entry	EExd - M20 x 1.5 conduit entry FM/CSA - 1/2 NPT conduit entry
Air Supply	80 psi/5.5 bar nominal
Air Entry	EExd (AP & MP) G ¹ / ₄ (HP) 3/8 NPT
Supply Pressure Regulation	20-150 psi/1.4 to 10 bar
Working Temperature	-40°C to 85°C
	Instrument quality dry clean air obligatory (Class 3.4.4 ISO 8573.1)



Ultimate Mounting Flexibility

- Low cost direct mount flange and coupling for mounting to valves with ISO 5211 drive interfaces, available for actuator models 03, 05, 07 and 09
- Mounting directly to standard Kinetrol double acting actuator there by reducing stocking requirements
- Multiple mounting hole sets in one part
- International patents.** The novel design allows metric mounting screws to face in either direction. Valve flanges with tapped holes can easily be interfaced for the first time. Nut recesses in flange make for easy installation
- Robust epoxy coated zinc alloy adaptor with no threads for maximum corrosion resistance**
- Female drive bi-square (star) coupling is retained by adaptor and made from zinc plated steel** (other materials available on request)
- Serrated drive versions also available.**



International Patents

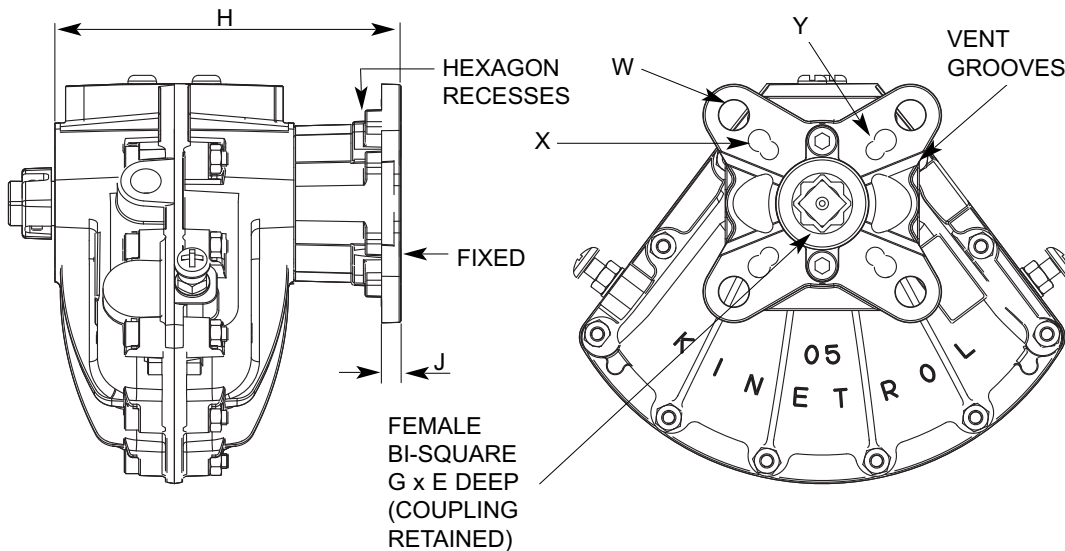

Adaptor Kit*	Order Codes	ISO Flange Sizes	H mm	J mm	G mm	E mm	W PCD mm	X PCD mm	Y PCD mm	WEIGHT kg
SP 1449	033F100**	F03/F05	84	5.0	11	12	6.6 50	5.5 36	-	0.13
SP 1454	034-100Z fitted with SP1454	F04	84	5.0	11	12	5.5 42	-	-	0.13
SP 1450	053F100	F04/F05/F07	97	5.4	14	17	9.0 70	6.6 50	5.5 42	0.27
SP 1451	073F100	F05/F07	140	8	17	19	9.0 70	6.6 50	-	0.53
SP 1452	093F100	F07/F10	176	10	22	24	11.0 102	9.0 70	-	1.04

* ANSI (e.g. ASP1449) colour versions (identical dimensions) also available.
 ** Default 03 version



If you want to operate a valve manually, but maintain the advantage of the fail-safe spring's certainty of position when unattended, use this device.

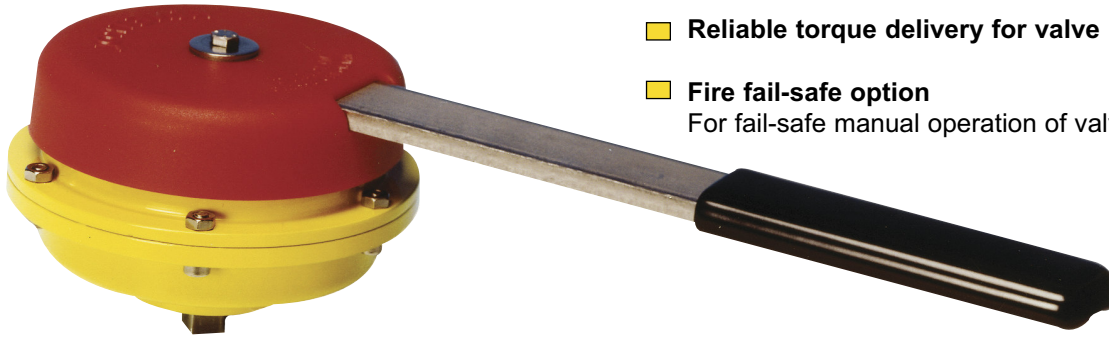

- Manual unit cannot be left in the wrong position
- Reliable torque delivery for valve reset
- Fire fail-safe option
For fail-safe manual operation of valves etc.

- ISO5211 female drive & ATEX Category 2 approved options available for models 02, 03, 05 and 07
- Clockwise or counter clockwise 90° spring action (02 reversible without the need for spring removal)
- Weatherproof sealed spring housing to protect from internal corrosion
- Bi-square (star) and serrated female drive options available

Application

Manual fail-safe spring units are available in Kinetrol sizes 02, 03, 05 and 07 with factory adjusted torques from 1.4Nm to 45.5Nm.

Models 05, 09 and 12 fire fail-safe units (maximum torque to 260Nm/2300 lbf ins) are available - contact Kinetrol for details.

Specification

Spring Case	Die cast zinc alloy with epoxy paint finish
Shaft	Stainless steel or carbon steel zinc plated
Lever	Stainless steel (03 & 05) Aluminium (02)

Optional fusible link	Soldered type (or equivalent) 2 options	
Yield temperature °C	72	93
Max normal ambient temperature °C	42	63

ISO/Female Drive Versions

The 03, 05 and 07 models are available with female drives for direct mount. The model 03 has F03/05 or F04 mounting flanges, the model 05 has F03/05/07 or F04 flanges and the model 07 has a F05/07 flange.

To order female drive versions, replace the 'O-' in the product code with '1F'. For example a model 05 ISO female drive manual fail-safe cw handle with F03/05/07 flanges is coded: 053F020-1006. The F04 flange version is coded 053F020-1006/F4.

Female drive versions with the same flange dimensions are available with ANSI threads eg 057F020-1006/F4.

Serrated female drive options can also be supplied for models 05 and 07. To order these replace the 'F' in the product code with an 'S'.

Ordering Codes

To order a manual fail-safe spring unit, quote model number, direction of spring (as per technical data on page 4) followed by product code.

- Type Codes:
- 1006 - spring unit
 - 1201 - single spring fire fail-safe unit (72°C link)
 - 1203 - double spring fire fail-safe unit (72°C link)
 - 1204 - single spring fire fail-safe unit (93°C link)
 - 1206 - double spring unit (93°C link)

When ordering fire fail-safe units, please state maximum torque required (at or below maximum shown in table).

Example: for an 05 model, ISO threads, spring clockwise, 15Nm maximum torque, the code would be:
054-020-1201 -15Nm

ATEX category 2 versions can be ordered by replacing "0" in code 1006 with "1" (i.e 1016)



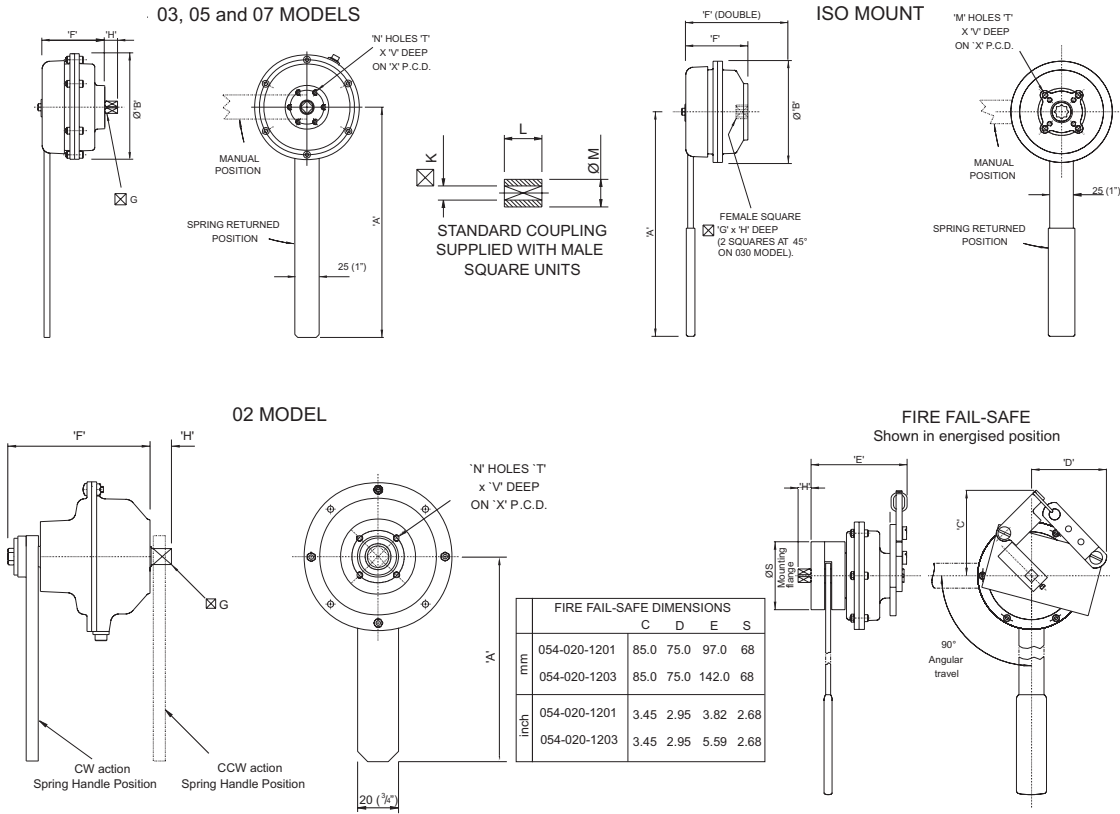

Dimensions/Torques

Metric Units

No Of Springs	A mm	B mm	F mm	G mm	H mm	K mm	L mm	M mm	N	T	V mm	X mm	Maximum Torque Nm	Torque Reduction Thro' Stroke Nm	
024-020-1006	1	110.0	73.0	70.0	7.98 7.93	10.0	8.022 8.000	22.0	16.0	4	M4	8.0	25.5	5.1	1.0
034-020-1006	1	238.0	108.0	62.0	8.98 8.93	12.0	9.022 9.000	22.0	18.0	4	M5	10.0	31.1	14.0	3.0
054-020-1006	1	238.0	118.0	62.0	9.525 9.470	13.0	9.58 9.55	25.4	19.0	6	M5	8.0	34.9	24.0	3.5
074-020-1006	1	360.0	152.0	103.0	15.98 15.93	-	16.027 16.000	40.0	32.0	4	M8	15	50.8	45.5	5.8
054-020-1201	1	238.0	118.0	79.0	9.525 9.470	13.0	9.58 9.55	25.4	19.0	6	M5	13.0	34.9	24.0	3.5
054-020-1203	2	238.0	118.0	124.0	9.525 9.470	13.0	9.58 9.55	25.4	19.0	6	M5/M6	13.0	34.9	45.5	5.8
033F020-1006	1	238.0	108.0	66.0	11.0	12.0	-	-	-	4	M5/M6	10/12	36/50	14.0	3.0
033F020-1006/F4	1	238.0	108.0	66.0	11.0	12.0	-	-	-	4	M5	10.0	42.0	14.0	3.0
053F020-1006	1	238.0	118.0	62.0	14.0	16.0	-	-	-	4	M5/M6/M8	10/12/13	36/50/70	24.0	3.5
053S020-1006	1	238.0	118.0	62.0	*	*	-	-	-	4	M5/M6/M8	10/12/13	36/50/70	24.0	3.5
053F020-1006/F4	1	238.0	118.0	62.0	14.0	16.0	-	-	-	4	M5	10.0	42.0	24.0	3.5
073F020-1006	1	360.0	152.0	103.0	17.0	22.0	-	-	-	4	M6/M8	14	50/70	45.5	5.8
073S020-1006	1	360.0	152.0	103.0	*	*	-	-	-	4	M6/M8	14	50/70	45.5	5.8

English Units

No Of Springs	A inch	B inch	F inch	G inch	H inch	K inch	L inch	M inch	N	T UNC	V inch	X inch	Maximum Torque lbs.ins	Torque Reduction Thro' Stroke lbs.ins	
027-020-1006	1	4.33	2.87	2.76	0.314 0.312	0.39	0.316 0.315	0.86	0.63	4	8-32	0.310	1.0	45	8.00
037-020-1006	1	9.37	4.25	2.44	0.354 0.352	0.47	0.355 0.354	0.86	0.70	4	10-24	0.390	1.22	124	26.55
057-020-1006	1	9.37	4.64	2.44	0.375 0.373	0.51	0.377 0.376	1.00	0.75	6	10-24	0.310	1.37	212	31.00
077-020-1006	1	14.17	5.98	4.06	0.629 0.627	-	0.631 0.630	1.57	1.26	4	5/16-18	0.625	2.00	400	51.00
057-020-1201	1	9.37	4.64	3.11	0.375 0.373	0.51	0.376 0.377	1.00	0.75	6	10-24	0.510	1.37	212	31.00
057-020-1203	2	9.37	4.64	4.88	0.375 0.373	0.51	0.377 0.376	1.00	0.75	6	10-24	0.510	1.37	425	51.00
037F020-1006	1	9.37	4.25	2.60	0.43	0.47	-	-	-	4	10-24	0.310/0.39	1.42/1.97	124	26.55
037F020-1006/F4	1	9.37	4.25	2.60	0.43	0.47	-	-	-	4	10-24	0.390	1.65	124	26.55
057F020-1006	1	9.37	4.64	2.44	0.55	0.63	-	-	-	4	10-24/1/4/5/16	0.39/0.47/0.51	1.42/1.97/2.76	212	30.98
057S020-1006	1	9.37	4.64	2.44	*	*	-	-	-	4	10-24	0.39/0.47/0.51	1.42/1.97/2.76	212	30.98
057F020-1006/F4	1	9.37	4.64	2.44	0.55	0.63	-	-	-	4	10-24	0.390	1.65	212	30.98
077F020-1006	1	14.17	5.98	4.06	0.669	0.75	-	-	-	4	1/4/5/16	0.39/0.51	1.97/2.76	400	51.00
077S020-1006	1	14.17	5.98	4.06	*	*	-	-	-	4	1/4/5/16	0.39/0.51	1.97/2.76	400	51.00

* Refer to TD141 for details on serrations and inserts

Weights - Metric

- 02 Models - 0.5 Kg
- 03 Models - 1.87 Kg
- 05 Models - 1.87 Kg
- 07 Models - 5.17 Kg

Weights - English

- 02 Models - 1.102 lb
- 03 Models - 4.123 lb
- 05 Models - 4.123 lb
- 07 Models - 11.374 lb





- **Simple compact unit**
No external moving parts
- **Unique linkage design**
converts to 180° travel
- **Constant gear-up ratio through travel range**
Hence constant output torque
- **Rolling contact linkage mechanism**
Ensures low wear, long life, low friction
- **Linkage sealed for life**
Protected from the environment, long maintenance free life
- **Compatible with all Kinetrol modules**
Direct mounted spring returns, limit switch boxes, positioners etc.
- **Adjustable endstops**
Giving up to 200° of travel

Operation

KINETROL'S 180° actuator is produced by adding a 2.1 step-up linkage onto the output shaft of well proven 90° vane actuators.

Factory fitted, direct mount linkage units are available to suit model 02, 03,05,07,09,12,14 and 16 actuators, giving a neat single unit with no mount kits or brackets. The linkages unique geometry gives constant 2:1 step-up so that the output torque may be constant throughout the actuator's travel.

The all-steel mechanism of the linkage employs rolling contacts to minimise frictional losses and wear, and to maximise life. The linkage is lubricated for life, and encased in a robust fully sealed die cast zinc alloy casing. Exterior surfaces are protected by a corrosion resistant epoxy stove enamel finish. Standard adjustable endstops on the 90 degree actuator can be used to set the angle of travel. The other end of the 90 degree actuator allows the full range of Kinetrol modular accessories to be fitted directly.

120 degree actuators are also available for the above model range - contact Kinetrol for details.

Ordering Codes

To order a 180° actuator, add a '1' to the end of the code for the 90° actuator on which it is based. Example:

To order an 074 cw spring return actuator plus 180° linkage, use code: 074-1201.



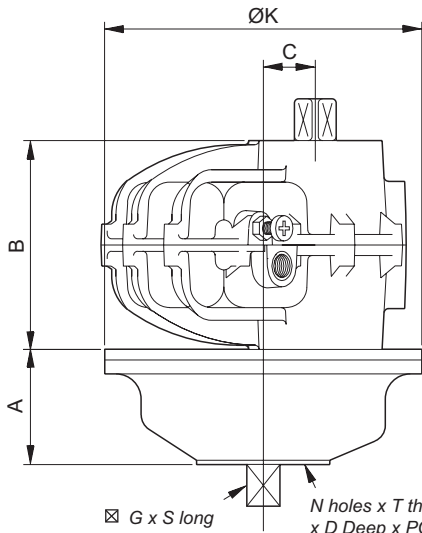

⊠ G x S long
Output square is shown at limit of travel (orientation is offset 45° to actuator shaft)

N holes x T thread x D Deep x PCD
Mounting holes are aligned with actuator interface

Metric Units

Actuator Model	A mm	B mm	C mm	K mm	G mm	S mm	N ISO	T mm	D mm	PCD mm	W kg
02 - 1001	32	50	12.5	73	8.0	10.0	4 M4	8.0	25.5	1.10	
03 - 1001	36	60	20	108	9.0	12.0	4 M5	10.0	31.1	2.00	
05 - 1001	35	67	20	108	9.5	13.0	6 M5	8.0	34.9	2.50	
07 - 1001	59	100	25	152	16.0	20.0	4 M8	16.0	50.9	5.90	
09 - 1001	70	126	35	200	19.0	26.0	4 M10	20.0	65.0	13.20	
12 - 1001	99	156	45	258	25.0	31.0	4 M12	22.0	77.8	25.45	
14 - 1001	122	200	70	394	28.6	38.0	4 M16	28.5	98.8	51.00	
16 - 1001	176	274	100	520	41.0	55.0	4 M24	38.0	152.7	125.00	

English Units

Actuator Model	A inch	B inch	C inch	K inch	G inch	S inch	N UNC	T inch	D inch	PCD inch	Wt lbs
02 - 1001	1.24	1.97	0.49	2.87	0.315	0.39	4 8-32	0.31	1.000	2.43	
03 - 1001	1.40	2.36	0.79	4.25	0.354	0.47	4 10-24	0.39	1.225	4.41	
05 - 1001	1.38	2.64	0.79	4.25	0.375	0.51	6 10-24	0.31	1.375	5.51	
07 - 1001	2.32	3.94	0.98	6.00	0.630	0.79	4 7/16-18	0.63	2.000	13.01	
09 - 1001	2.76	4.96	1.38	7.90	0.748	1.02	4 1/2-16	0.79	2.560	29.10	
12 - 1001	3.90	6.14	1.77	10.16	0.984	1.22	4 1/2-13	0.87	3.060	56.11	
14 - 1001	4.79	7.87	2.76	15.50	1.125	1.50	4 7/8-11	1.13	3.890	112.43	
16 - 1001	6.93	10.79	3.94	20.47	1.614	2.17	4 7/8-9	1.5	6.012	275.00	

N.B. Weights are inclusive of actuator and 180 degree assembly, coupling and indicator (except models 14 & 16).

Double Acting Torques/Metric Units Nm

Actuator Model	Pressure (bar)								
	1.4	2.0	2.8	3.5	4.1	4.8	5.5	6.2	6.9
02-1001	0.6	1.1	1.6	2.2	2.7	3.2	3.7	4.2	4.8
03-1001	1.3	2.4	3.5	4.6	5.6	6.7	7.8	8.8	10.0
05-1001	3.2	5.2	7.2	9.3	11.3	13.6	15.6	17.8	19.9
07-1001	7.9	12.6	17.6	22.6	27.6	33.0	38.4	43.2	48.8
09-1001	16.3	20.0	37.1	47.6	58.0	69.2	80.4	91.2	103.0
12-1001	37.5	60.8	84.4	108.0	131.0	156.0	181.0	202.0	226.0
14-1001	97.2	151.0	206.0	262.0	316.0	375.0	434.0	488.0	542.0
16-1001	235.0	357.0	479.1	605.7	727.7	849.8	976.3	1098.4	1220.4

Double Acting Torques/English Units lbf ins

Actuator Model	Pressure (psi)								
	20	30	40	50	60	70	80	90	100
02-1001	5.6	10	14	19	24	28	33	37	42
03-1001	12	21	31	40	50	59	69	78	88
05-1001	28	46	64	82	100	120	138	157	176
07-1001	70	112	156	200	244	292	340	384	432
09-1001	144	236	328	420	512	612	712	808	912
12-1001	332	540	748	960	1160	1376	1588	1792	2000
14-1001	860	1340	1820	2320	2800	3320	3840	4320	4800
16-1001	2080	3160	4240	5360	6440	7520	8640	9720	10800

Spring Return Torques Metric Units Nm

Actuator Model	Position of air OR spring stroke	Pressure Setting (bar)				
		3.5	4.0	4.5	5.0	5.5
02-1201	Start	1.1	1.3	1.4	1.6	1.8
	Finish	0.5	0.7	0.9	1.2	1.4
03-1201	Start	3.3	3.7	4.0	4.3	4.9
	Finish	1.0	1.5	1.9	2.2	2.8
05-1201	Start	4.9	5.5	6.2	7.0	7.9
	Finish	3.2	4.0	4.9	5.8	6.7
07-1201	Start	11.6	13.5	15.5	17.4	19.3
	Finish	7.5	9.5	11.6	13.8	16.1
09-1201	Start	23.2	27.4	31.1	35.3	39.5
	Finish	19.1	23.2	27.0	31.4	35.6
12-1201	Start	55.1	64.8	75.6	81.1	90.4
	Finish	42.2	52.0	60.0	68.9	77.5
14-1201-4900	Start	135.0	156.0	178.0	195.0	201.0
	Finish	109.0	131.0	148.0	164.0	170.0
16-1201	Start	346.8	391.0	426.0	465.0	504.3
	Finish	181.4	237.0	282.0	332.0	381.9

Spring Return Torques English Units lbf ins

Actuator Model	Position of air OR spring stroke	Pressure Setting (psi)			
		50	60	70	80
02-1201	Start	10.3	12.2	14.1	16.0
	Finish	4.6	6.8	9.5	12.5
03-1201	Start	29.6	33.4	37.2	43.7
	Finish	8.7	13.7	19.0	24.7
05-1201	Start	44	51	61	70
	Finish	28	38	49	59
07-1201	Start	103	126	146	171
	Finish	67	92	116	143
09-1201	Start	205	251	300	351
	Finish	169	215	266	315
12-1201	Start	486	595	693	802
	Finish	374	479	585	688
14-1201-4900	Start	1200	1420	1670	1780
	Finish	969	1200	1400	1500
16-1201	Start	3069	3534	3998	4463
	Finish	1605	2197	2788	3380



Model OMO (miniature)

Specification

Output Torque

8.0 lbf ins/0.9 Nm
at 100 psi/7 bar

Angle of Travel (adjustable)

80° - 100°
(restricted travel
versions available)

Displaced Volume

0.15 in³/2.4 cm³

Finish

Epoxy stove enamel

Weight

0.26 lb/0.12 kg

For further information
see General Specification
on page 50.

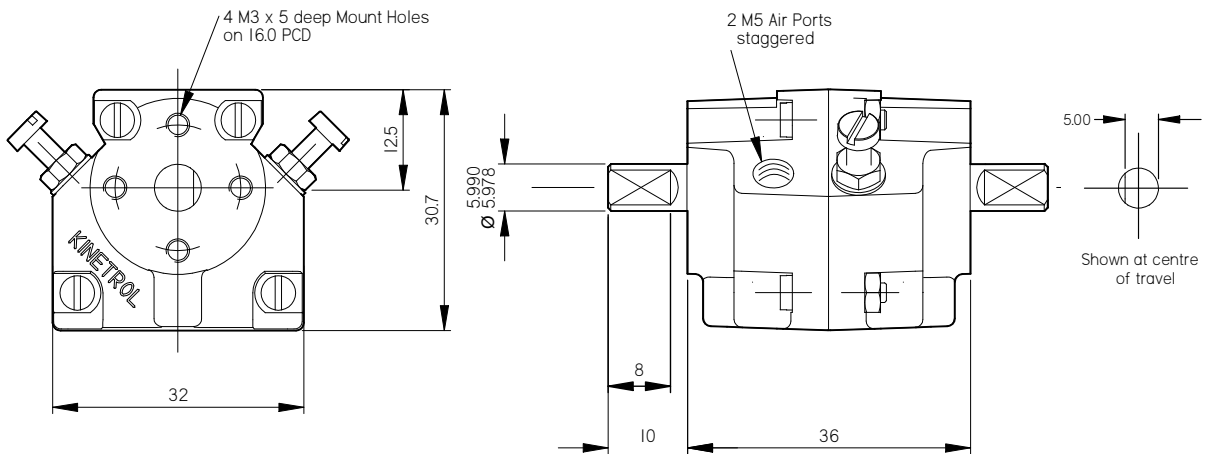
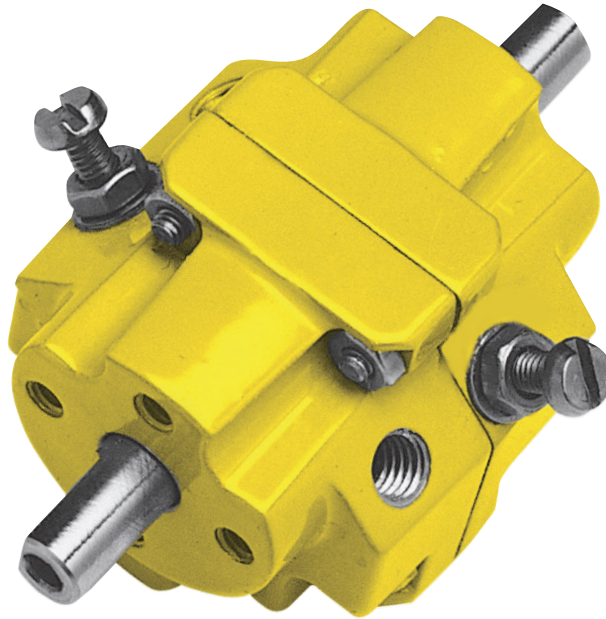

Options

- Code identification see page 53
- Torque outputs see pages 51/52
- English dimensions see page 44



014-100



014P100

Standard Coupling
(supplied with both actuator types
weight 0.2 oz/0.005 kg)

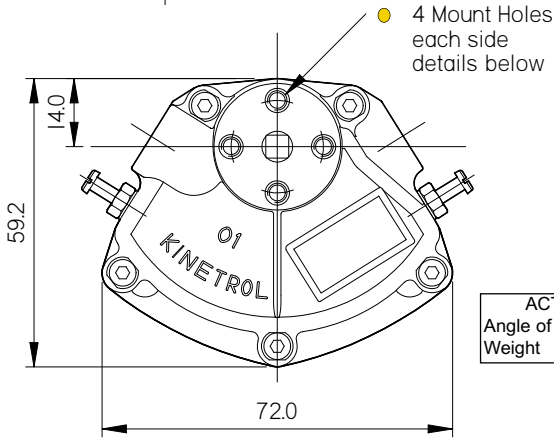
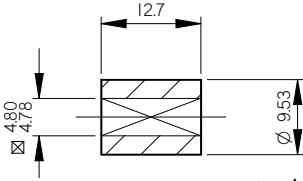

ACTUATOR 014-100
Angle of travel: 78° - 100°
Weight 0.62 lb/0.28 kg

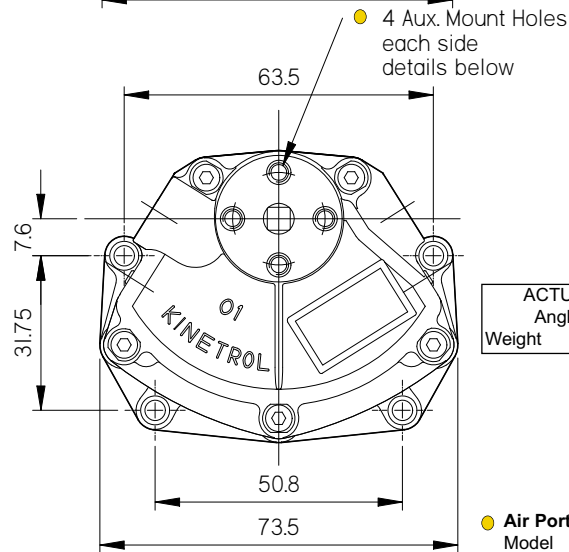

ACTUATOR 014P100
Angle of travel: 90°
Weight 0.77 lb/0.34 kg

Air Port/Mount Hole Details

Model	Air Ports	Mount Holes
014-100	G ¹ / ₈	M4 x 6 deep on 19.0 PCD
017-100	1/8 NPT	8-32 UNC x 0.25" deep on 0.75" PCD
014F100	G ¹ / ₈	M4 clearance

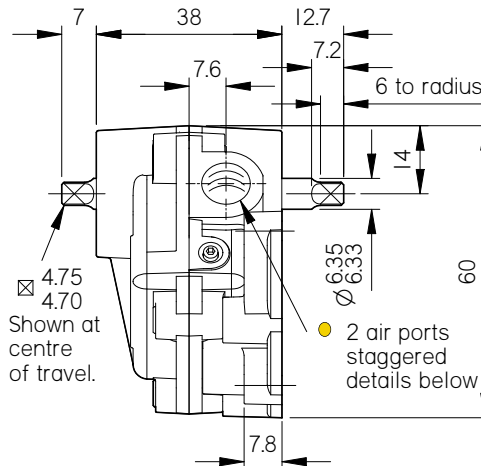
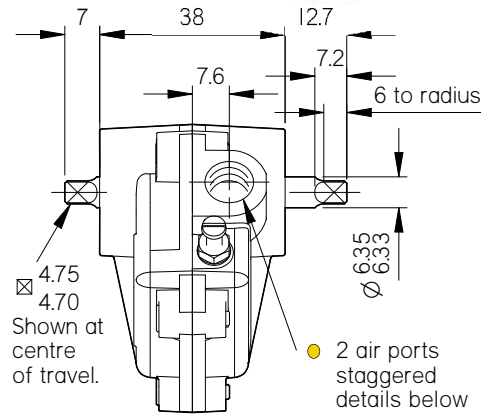

Specification

Output Torque

58 lbf ins/6.7 Nm
at 100 psi/7 bar

Angle of Travel

See Drawings
(restricted travel
versions available)

Displaced Volume

1.00 in³/16.5 cm³

Finish

Epoxy stove enamel

Weight

See Drawings

For further information
see General Specification
on page 50.

Options

- Conversion kit between two types. SP870
- Fail safe spring return units - clockwise or counter clockwise
- Code identification see page 53
- Torque outputs see pages 51/52
- See page 44 for English dimensions and TD121 page 4 for dimensions of spring options



Model 02

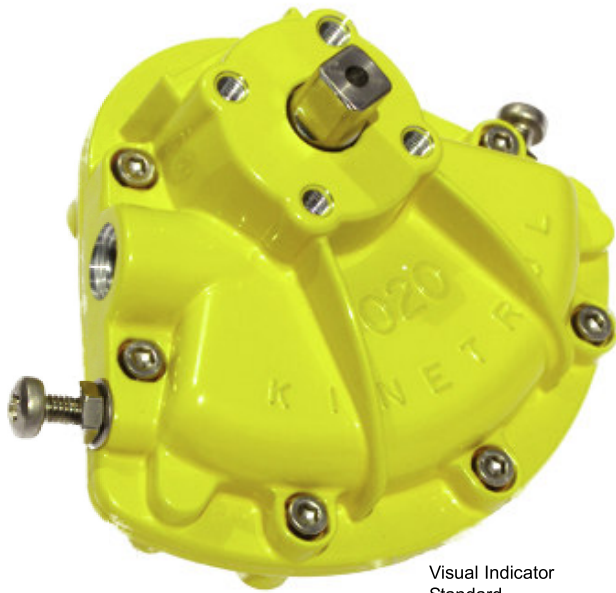

Visual Indicator Standard

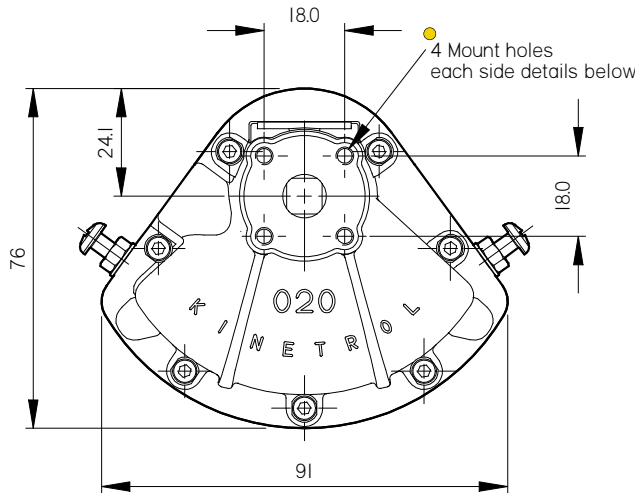
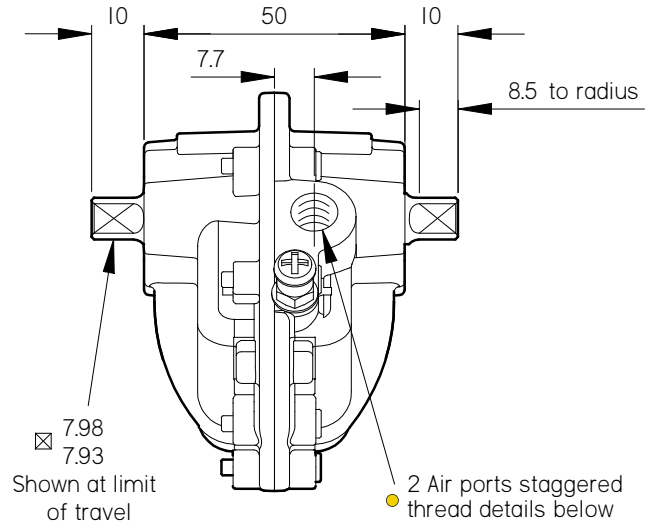
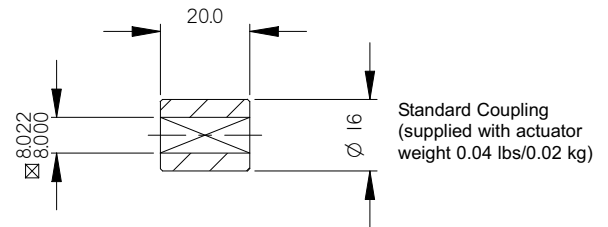

Air Port/Mount Hole Details

Model	Air Ports	Mount Holes
024-100	G ¹ / ₈	M4 x 8 deep on 25.5 PCD
027-100	1/8 NPT	8-32 UNC x 0.32" deep on 1.00" PCD

Specification

Output Torque

106 lbf ins/12.1 Nm
at 100 psi/7 bar

Angle of Travel (adjustable)

80° - 100°
(restricted travel versions available)

Displaced Volume

1.89 in³/31 cm³

Finish

Epoxy stove enamel

Weight

0.97 lb/0.44 kg
(excluding coupling)

For further information see General Specification on page 50.

Options

- Fail safe spring return units - clockwise or counter clockwise
- 180° model
- Female drive and mounting details to DIN 3337 and ISO 5211
- Code identification see page 53
- Torque outputs see pages 51/52
- See pages 44-46 for English dimensions and dimensions of spring options



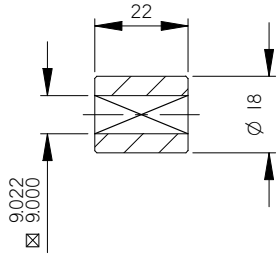

Standard Coupling
(supplied with actuator
weight 0.07 lbs/0.03 kg)

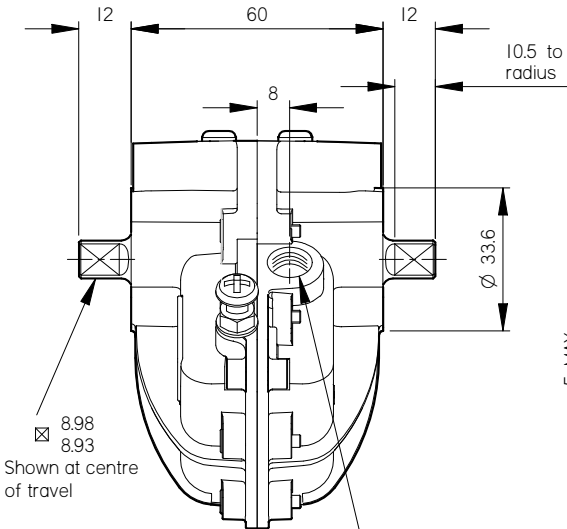
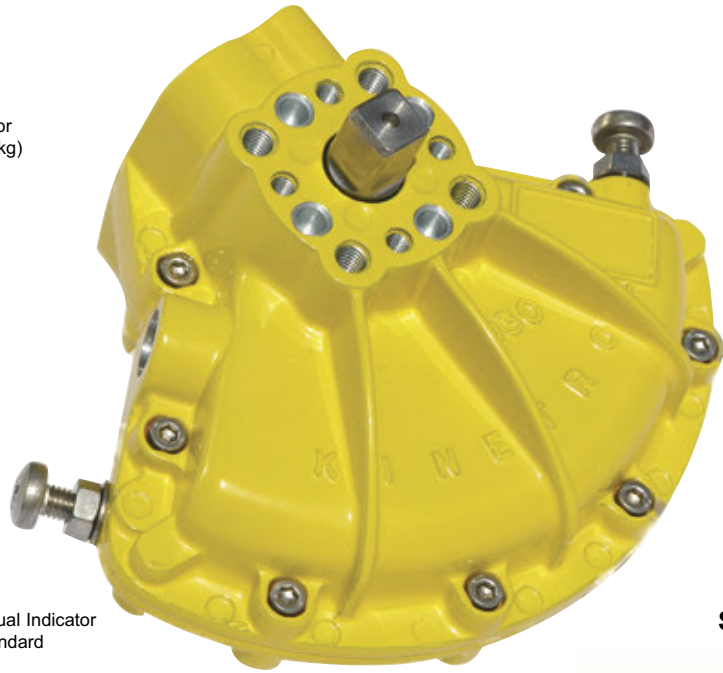

8.98
8.93
Shown at centre
of travel

2 Air ports staggered
thread details below

● Air Port/Mount Hole Details

Model	Air Ports	Mount Holes
034-100	G ¹ / ₈	M5 x 10 deep on 31.1 PCD
037-100	1/8 NPT	10-24 UNC x 0.39" deep on 1.225" PCD

Visual Indicator
Standard

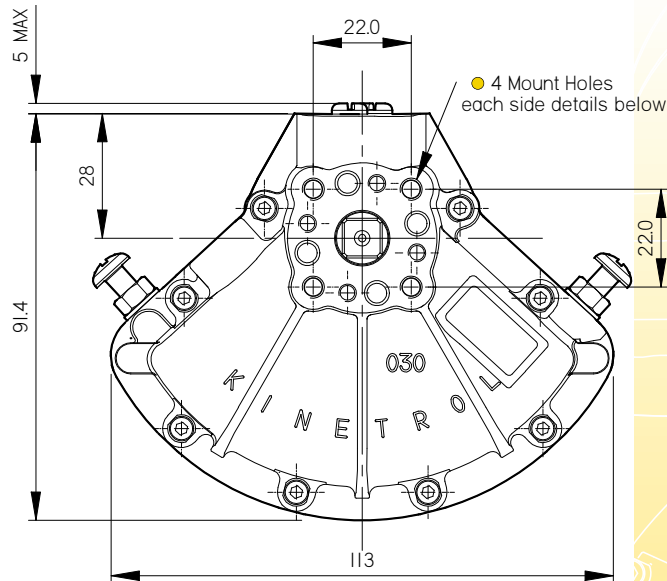

4 Mount Holes
each side details below

Specification

Output Torque

220 lbf ins/25 Nm
at 100 psi/7 bar

Angle of Travel (adjustable)

80° - 100°
(restricted travel
versions available)

Displaced Volume

3.66 in³/60 cm³

Finish

Epoxy stove enamel

Weight

1.53 lb/0.70 kg
(excluding coupling)

For further information
see General
Specification on
page 50.

Options

- Fail safe spring return units - clockwise or counter clockwise
- Limit switch boxes for open/close indication - various switches for hazardous areas
- Integral solenoid valve
- 180° model
- Female drive and mounting details to DIN 3337 and ISO 5211
- ISO adaptor
- Code identification see page 53
- Torque outputs see pages 51/52
- See pages 44-46 for English dimensions and dimensions of spring options
- High temperature



Model 05

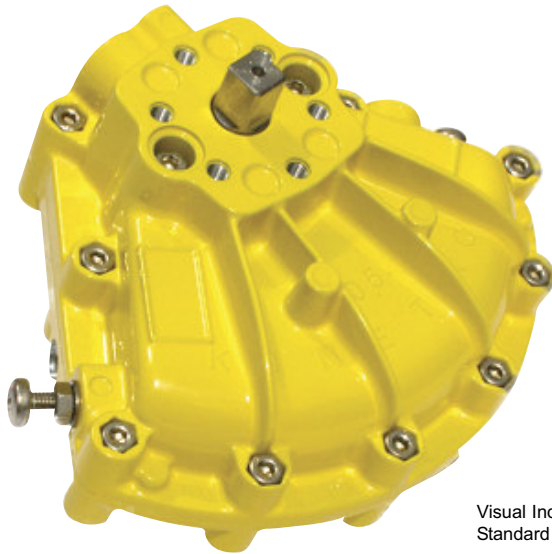

Visual Indicator Standard

Standard Coupling
(supplied with actuator weight 0.09 lbs/0.04 kg)

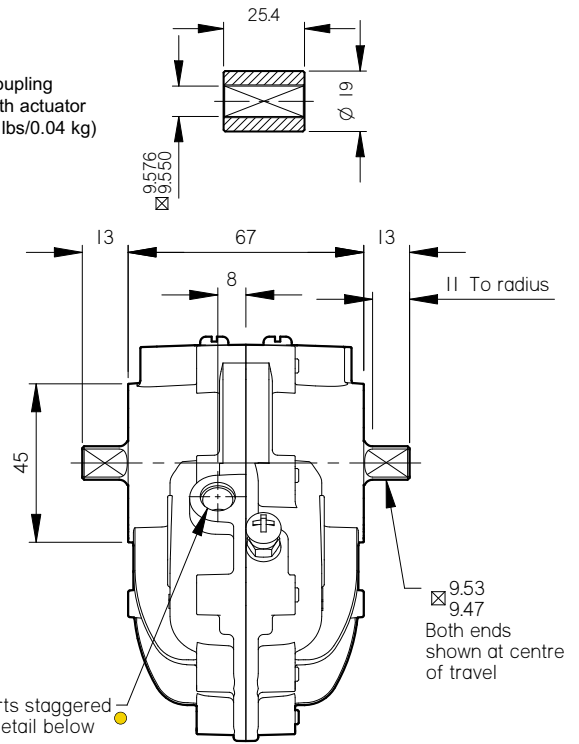

Specification

Output Torque

440 lbf ins/50 Nm
at 100 psi/7 bar

Angle of Travel (adjustable)

84° - 100°
(restricted travel versions available)

Displaced Volume

6.9 in³/113 cm³

Finish

Epoxy stove enamel

Weight

2.73 lb/1.24 kg
(excluding coupling)

For further information see General Specification on page 50.

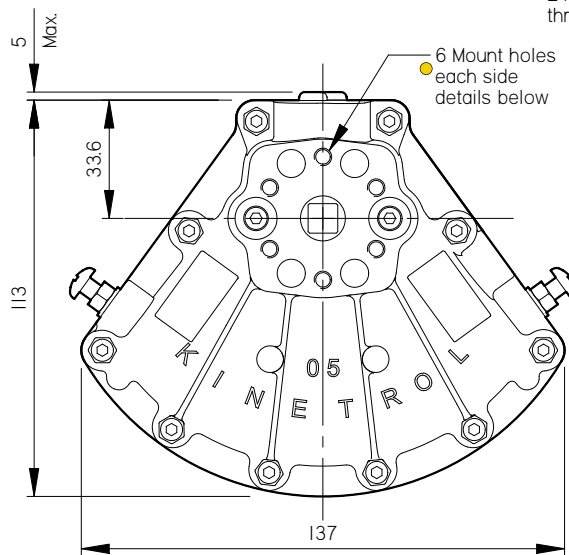

Air Port/Mount Hole Details

Model	Air Ports	Mount Holes
054-100	G ¹ / ₈	M5 x 10 deep on 34.9 PCD
057-100	1/8 NPT	10-24 UNC x 0.39" deep on 1.375" PCD

Options

- Fail safe spring return units - clockwise or counter clockwise
- Limit switch boxes for open/close indication - various switches for hazardous areas
- AP pneumatic positioner - full range of options see pages 17/18
- EL electropneumatic positioner - full range of options see pages 15/16
- Integral solenoid valve see page 6
- 3 stop positioner- full range of options see pages 13/14
- Clear Cone position monitor see page 6
- 180° model see pages 23/24
- Female drive and mounting details to DIN 3337 and ISO 5211 see page 44
- ISO adaptor see page 20
- Geared manual override see page 40
- Code identification see page 53
- Torque outputs see pages 51/52
- See pages 44-46 for English dimensions and dimensions of spring options
- High temperature



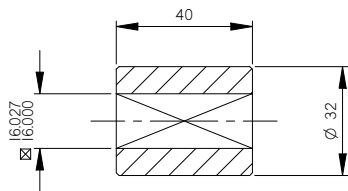

Standard Coupling
(supplied with actuator
weight 0.37 lbs/0.17 kg)

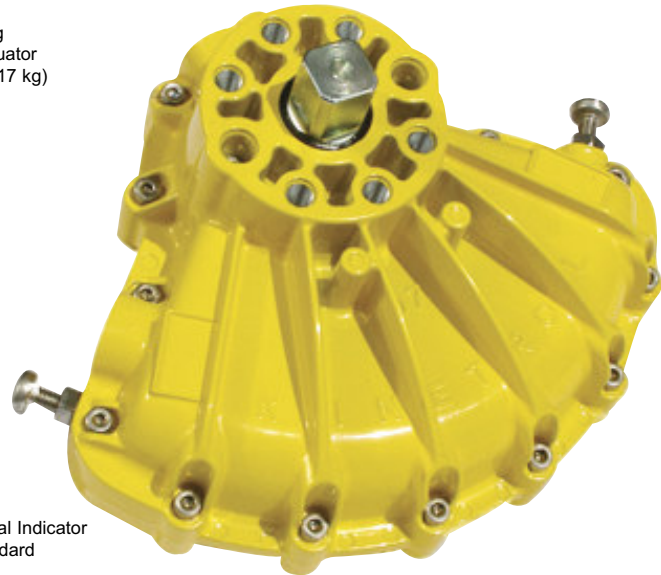

Visual Indicator
Standard

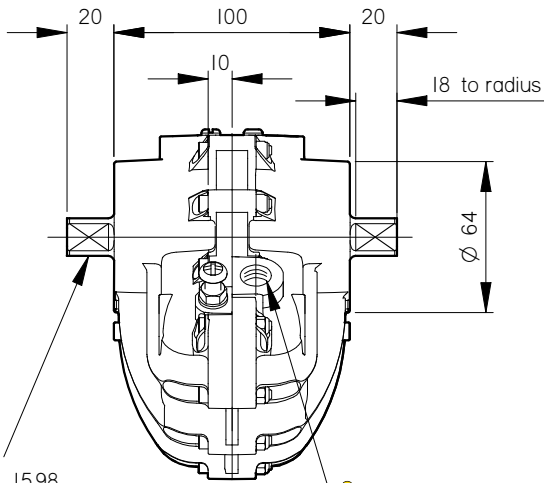

1598
1593
Shown at centre
of travel

2 Air ports staggered
thread details below

Air Port/Mount Hole Details

Model	Air Ports	Mount Holes
074-100	G ¹ / ₄	M8 x 16 deep on 50.8 PCD
077-100	1/4 NPT	5/16 UNC -18 x 0.63" deep on 2.00" PCD

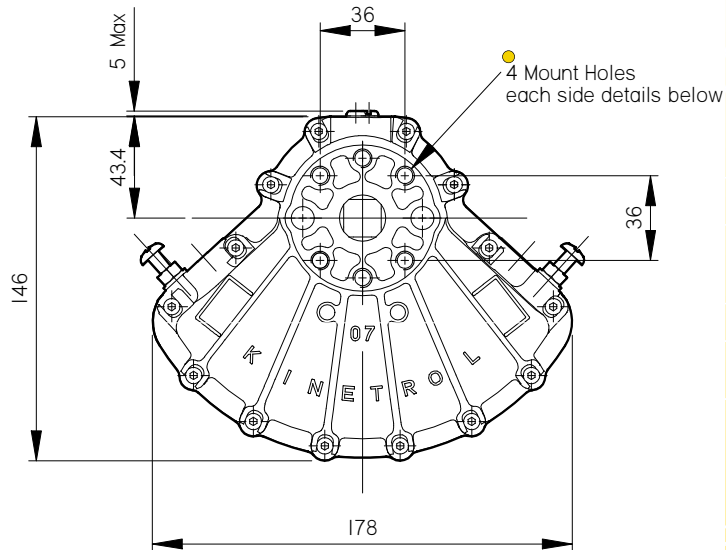

Options

- Fail safe spring return units - clockwise or counter clockwise
- Limit switch boxes for open/close indication - various switches for hazardous areas
- AP pneumatic positioner - full range of options see pages 17/18
- EL electropneumatic positioner - full range of options see pages 15/16
- Integral solenoid valve see page 6
- 3 stop positioner see pages 13/14
- Clear Cone position monitor see page 6
- 180° model see pages 23/24
- Female drive and mounting details to DIN 3337 and ISO 5211 see page 44
- ISO adaptor see page 20
- 3/8 ports
- Geared manual override see page 40
- Code identification see page 53
- Torque outputs see pages 51/52
- See pages 44-46 for English dimensions and dimensions of spring options
- High temperature

Specification

Output Torque

1080 lbf ins/124 Nm
at 100 psi/7 bar

**Angle of Travel
(adjustable)**

80° - 100°
(restricted travel
versions available)

Displaced Volume

18.3 in³/300 cm³

Finish

Epoxy stove enamel

Weight

6.91 lb/3.13 kg
(excluding coupling)

For further information
see General
Specification on
page 50.



Model 08



Standard Coupling
(supplied with actuator
weight 0.31 lbs/0.14 kg)

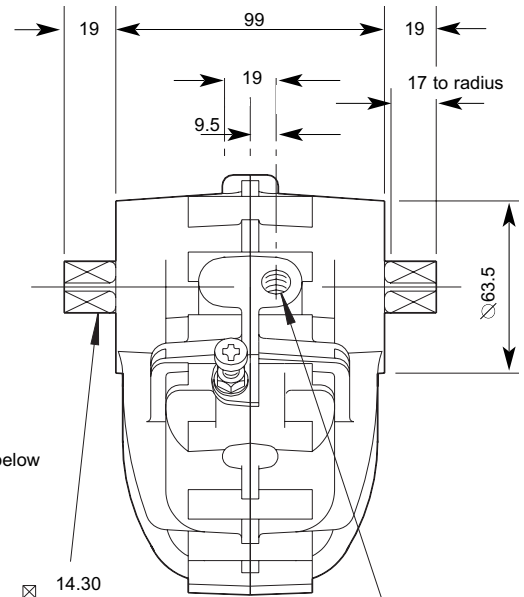
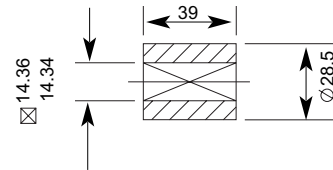

Specification

Output Torque

1500 lbf ins/173 Nm
at 100 psi/7 bar

Angle of Travel (adjustable)

72° - 93°
(restricted travel
versions available)

Displaced Volume

23.9 in³/392 cm³

Finish

Epoxy stove enamel

Weight

6.85 lb/3.11 kg
(excluding coupling)

For further information
see General Specification
on page 50.



6 Mount holes
each side details below

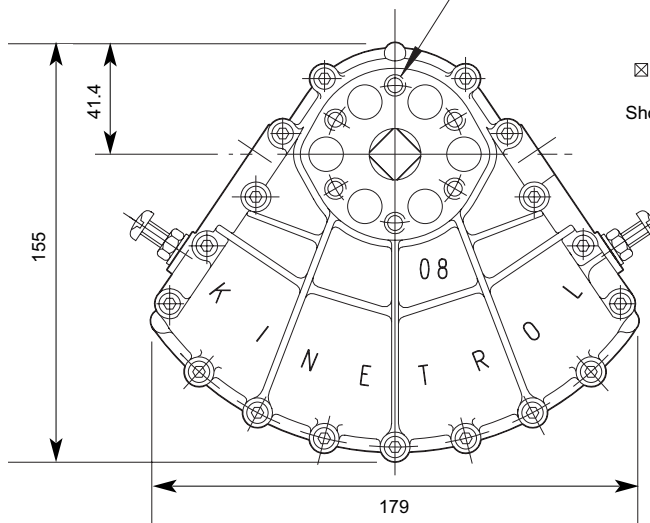

14.30
14.25
Shown at limit
of travel

2 Air ports staggered
thread details below

Air Port/Mount Hole Details

Model	Air Ports	Mount Holes
080-100	G ¹ / ₄	M8 x 16 deep on 50.8 PCD
089-100	1/4 NPT	5/16 UNC x 0.63" deep on 2.00" PCD

Options

- Fail safe spring return units - clockwise or counter clockwise
- Limit switch boxes for open/close indication - various switches for hazardous areas
- AP pneumatic positioner - full range of options see pages 17/18
- EL electropneumatic positioner - full range of options see pages 15/16
- Code identification see page 53
- Torque outputs see pages 51/52
- See pages 44-46 for English dimensions and dimensions of spring options

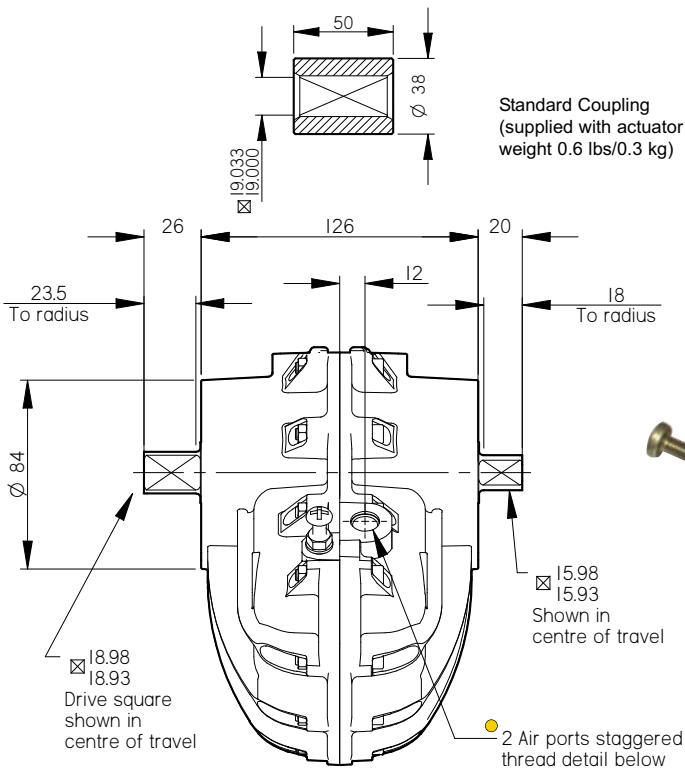

Visual Indicator Standard

● Air Port/Mount Hole Details

Model	Air Ports	Mount Holes & Accessory Mount Holes
094-100	G ¹ / ₄	4 x M10 x 20 deep on 65.0 PCD 2 x M8 x 16 deep on 50.8 PCD
097-100	1/4 NPT	4 x 3/8 UNC x 0.79" deep on 2.56" PCD 2 x 5/16 UNC -18 x 0.63" deep on 2.00" PCD

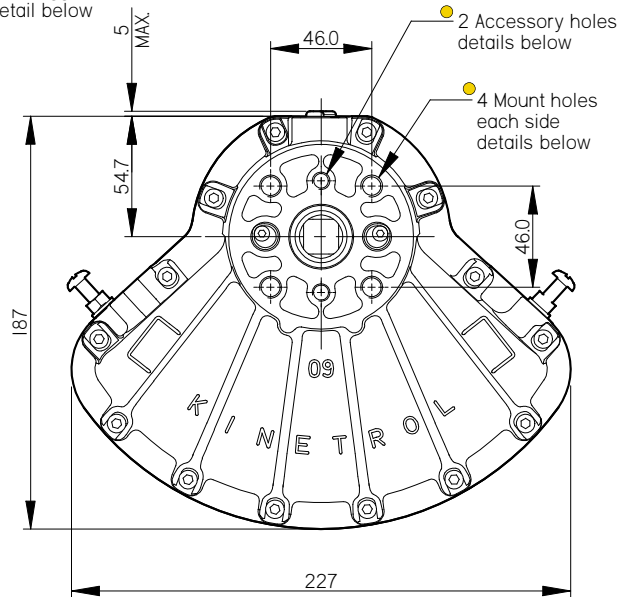

Options

- Fail safe spring return units - clockwise or counter clockwise
- Limit switch boxes for open/close indication - various switches for hazardous areas
- AP pneumatic positioner - full range of options see pages 17/18
- EL electropneumatic positioner - full range of options see pages 15/16
- Integral solenoid valve see page 6
- 3 stop positioner - full range of options see pages 13/14
- Clear Cone position monitor see page 6
- 180° model see pages 23/24
- Female drive and mounting details to DIN 3337 and ISO 5211 see page 44
- ISO adaptor see page 20
- 3/8" ports
- Geared manual override see page 40
- Code identification see page 53
- Torque outputs see pages 51/52
- See pages 44-46 for English dimensions and dimensions of spring options
- High temperature

Specification

Output Torque

2280 lbf ins/261 Nm
at 100 psi/7 bar

Angle of Travel
(adjustable)

80° - 100°
(restricted travel versions available)

Displaced Volume

39.3 in³/644 cm³

Finish

Epoxy stove enamel

Weight

8.52 lb/3.86 kg
(excluding coupling)

For further information see General Specification on page 50.



Model 10



Visual Indicator
Standard

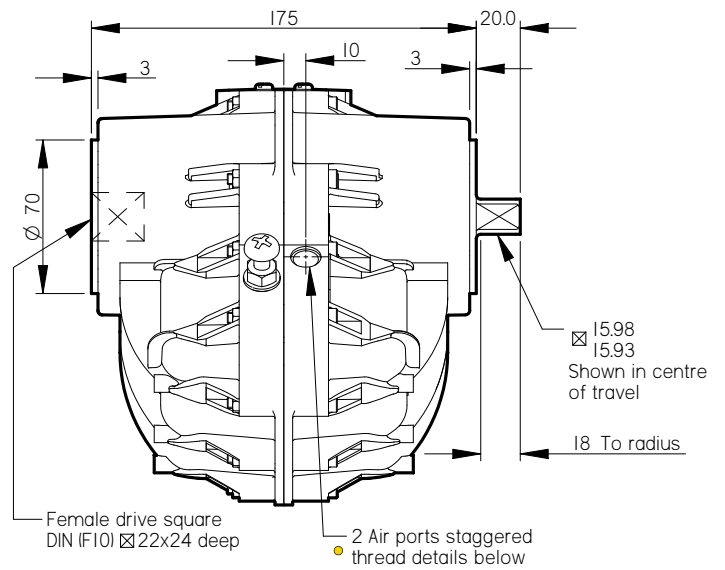

Specification

Output Torque

3625 lbf ins/416 Nm
at 100 psi/7 bar

Angle of Travel (adjustable)

78° - 100°
(restricted travel
versions available)

Displaced Volume

62.5 in³/1025 cm³

Finish

Epoxy stove enamel

Weight

21.2 lb/9.6 kg
(no coupling)

For further information
see General Specification
on page 50.

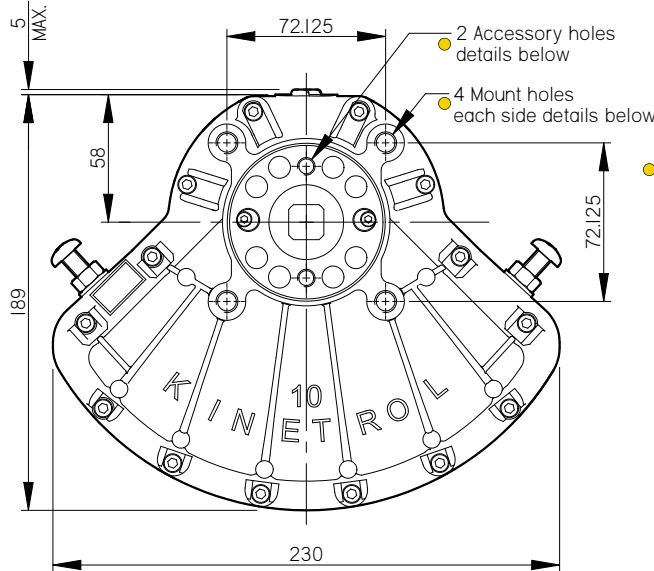

Air Port/Mount Hole Details

Model	Air Ports	Mount Holes & Accessory Mount Holes
103-100	G ¹ / ₄	4 x M10 x 16 deep on 102.0 PCD
107-100	1/4 NPT	2 x M8 x 16 deep on 50.8 PCD
		4 x 3/8 UNC x 0.63" deep on 4.02" PCD
		2 x 5/16 UNC -18 x 0.63" deep on 2.00" PCD

Female drive and mounting details to DIN 3337 and ISO 5211 as standard

Options

- Fail safe spring return units - clockwise or counter clockwise
- Limit switch boxes for open/close indication - various switches for hazardous areas
- AP pneumatic positioner - full range of options see pages 17/18
- EL electropneumatic positioner - full range of options see pages 15/16
- Integral solenoid valve see page 6
- 3 stop positioner- full range of options see pages 13/14
- Clear Cone position monitor see page 6
- Geared manual override see page 40
- Code identification see page 53
- Torque outputs see pages 51/52
- See pages 44-46 for English dimensions and dimensions of spring options
- High temperature



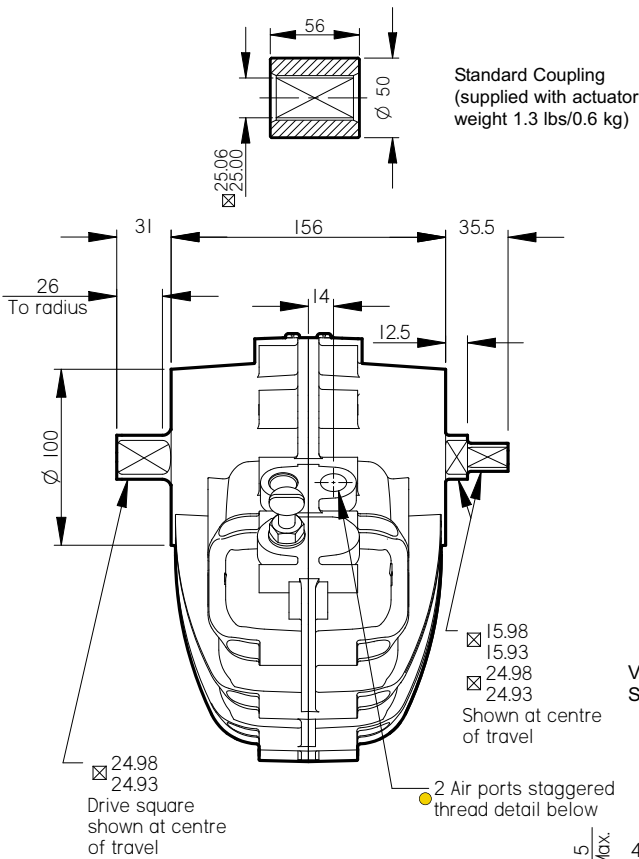

Visual Indicator
Standard

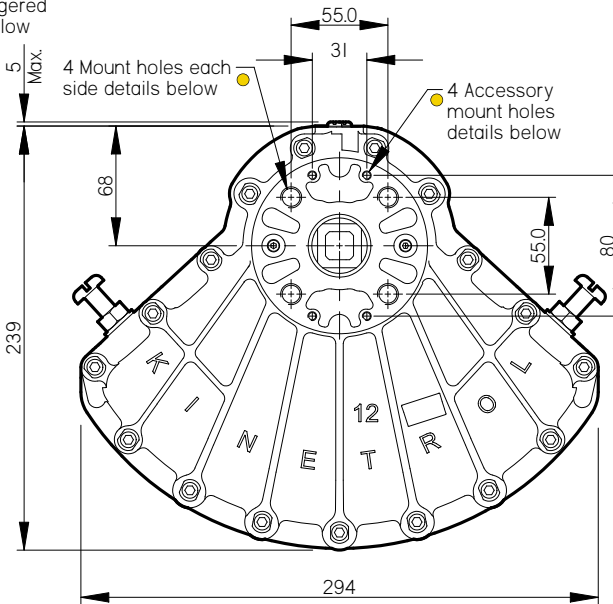

Air Port/Mount Hole Details

Model	Air Ports	Mount Holes & Accessory Mount Holes
124-100	G ³ / ₈	M12 x 24 deep on 77.8 PCD M5 x 10 deep
127-100	3/8 NPT	1/2 UNC x 0.94" deep on 3.06" PCD 10-24 x 3/8" deep

Options

- Fail safe spring return units - clockwise or counter clockwise
- Limit switch boxes for open/close indication - various switches for hazardous areas
- AP pneumatic positioner - full range of options see pages 17/18
- EL electropneumatic positioner - full range of options see pages 15/16
- Integral solenoid valve see page 6
- 3 stop positioner - full range of options see pages 13/14
- 180° model see page 23/24
- Female drive and mounting details to DIN 3337 and ISO 5211
- Geared manual override see page 40
- Code identification see page 53
- Torque outputs see pages 51/52
- See pages 44-46 for English dimensions and dimensions of spring options
- Accessory mount plate for positioners, switch boxes and clear cone monitor. See TD149.
- High Temperature

Specification

Output Torque

5000 lbf ins/575 Nm
at 100 psi/7 bar

Angle of Travel (adjustable)

80° - 102°
(restricted travel
versions available)

Displaced Volume

86 in³/1410 cm³

Finish

Epoxy stove enamel

Weight

15.2 lb/6.9 kg
(excluding coupling)

For further information
see General
Specification on
page 50.



Model 14



Standard Coupling
(supplied with actuator
weight 1.5 lbs/0.7 kg)

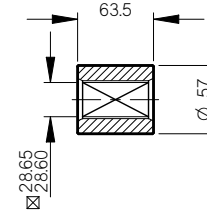

Visual Indicator
Standard

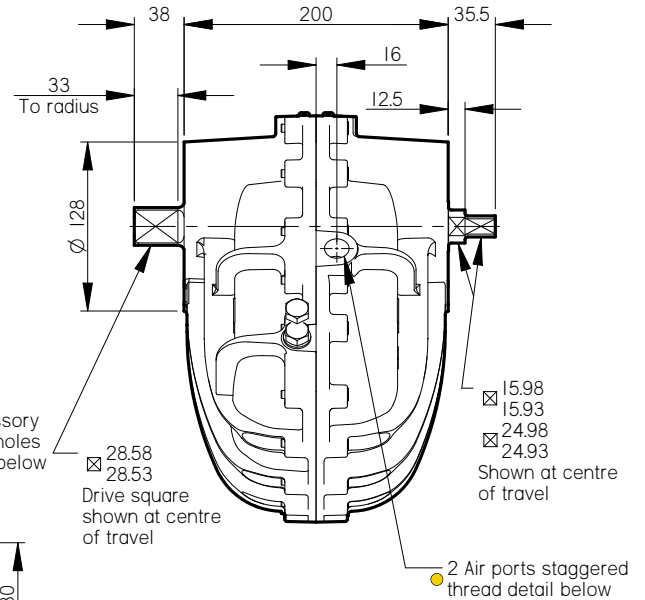

Specification

Output Torque

12000 lbf ins/1375 Nm
at 100 psi/7 bar

Angle of Travel (adjustable)

80° - 100°
(restricted travel
versions available)

Displaced Volume

201 in³/3294 cm³

Finish

Epoxy stove enamel

Weight

29.5 lb/13.4 kg
(excluding coupling)

For further information
see General Specification
on page 50.

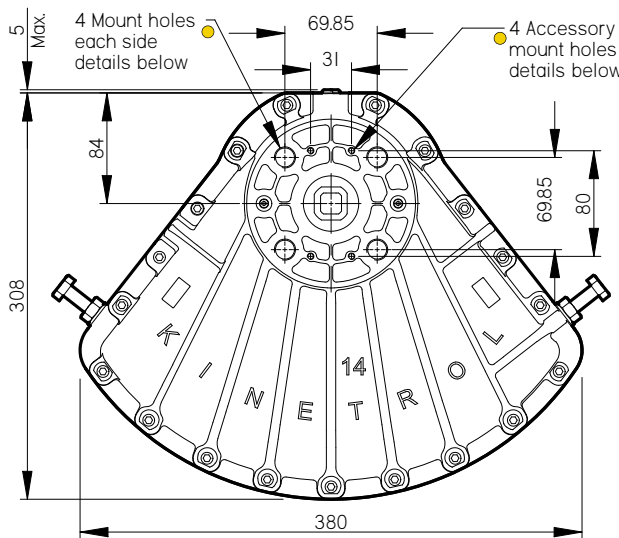

Air Port/Mount Hole Details

Model	Air Ports	Mount Holes & Accessory Mount Holes
144-100	G ¹ / ₂	M16 x 28 deep on 98.8 PCD M5 x 10 deep
147-100	1/2 NPT	5/8 UNC x 1.12" deep on 3.89" PCD 10-24 x 3/8" deep

Options

- Fail safe spring return units - clockwise or counter clockwise
- Limit switch boxes for open/close indication - various switches for hazardous areas
- AP pneumatic positioner - full range of options see pages 17/18
- EL electropneumatic positioner - full range of options see pages 15/16
- Integral solenoid valve see page 6
- 3 stop positioner - full range of options see pages 13/14
- 180° model see page 23/24
- Female drive and mounting details to DIN 3337 and ISO 5211
- Geared manual override see page 40
- Code identification see page 53
- Torque outputs see pages 51/52
- See pages 44-46 for English dimensions and dimensions of spring options
- Accessory mount plate for positioners, switch boxes and clear cone monitor. See TD149.
- High Temperature



Vane Slot detail both ends

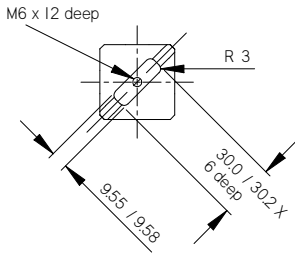

Standard Coupling
(supplied with actuator
weight 5.3 lbs/2.4 kg)

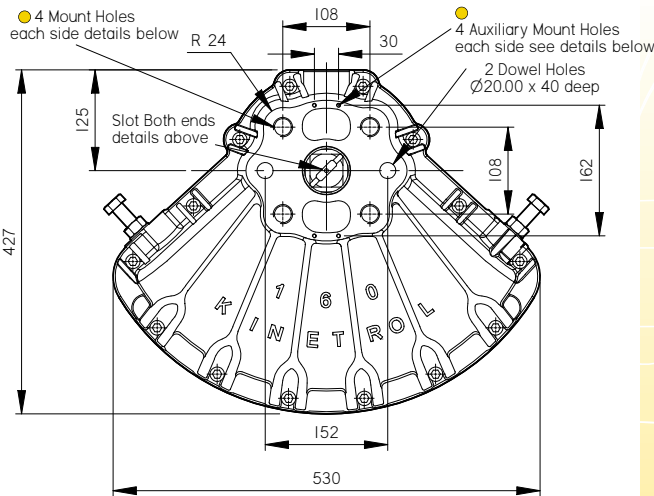
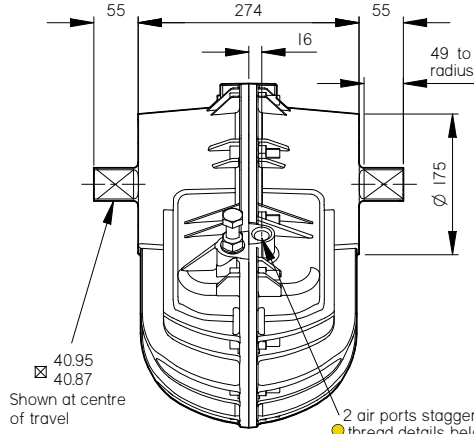
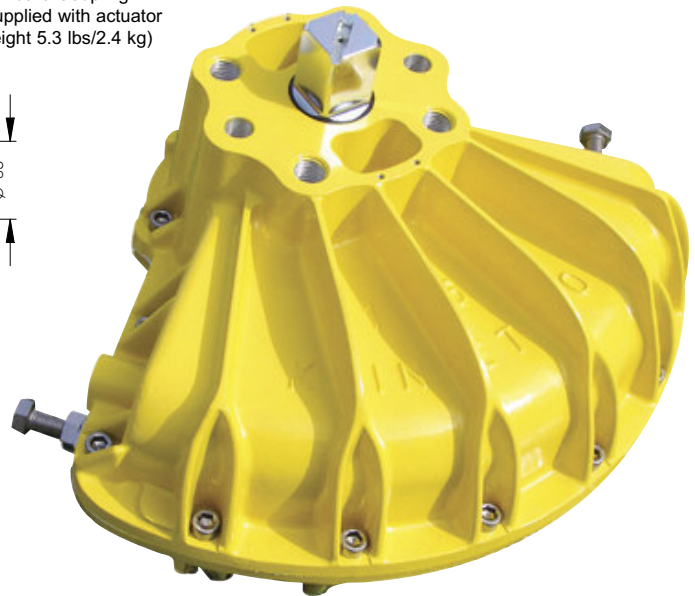
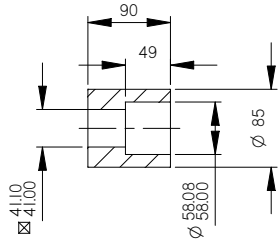

● Air Port/Mount Hole Details

Model	Air Ports	Mount Holes & Auxillary Mount Holes
164-100	G 1/2	M24 x 38 deep on 152.7 PCD M5 x 8 deep
167-100	1/2 NPT	7/8 UNC x 1.50" deep on 6.012" PCD 10-24 UNC x 0.31" deep

Specification

Output Torque

27000 lbf ins/3100 Nm
at 100 psi/7 bar

**Angle of Travel
(adjustable)**

80° - 100°
(restricted travel
versions available)

Displaced Volume

465 in³/7630 cm³

Finish

Epoxy stove enamel

Weight

82.5 lb/37.4 kg
(excluding coupling)

Options

- Fail safe spring return units - clockwise or counter clockwise
- Limit switch boxes for open/close indication - various switches for hazardous areas
- AP pneumatic positioner - full range of options see pages 17/18
- EL electropneumatic positioner - full range of options see pages 15/16
- 180° model see pages 23/24
- Female drive and mounting details to DIN 3337 and ISO 5211
- Geared manual override see page 40
- Code identification see page 53
- Torque outputs see pages 51/52
- See pages 44-46 for English dimensions and dimensions of spring options
- High temperature

For further information
see General
Specification on
page 50.



Model 18



Standard Coupling
(supplied with actuator
weight 13.7 lbs/6.2 kg)

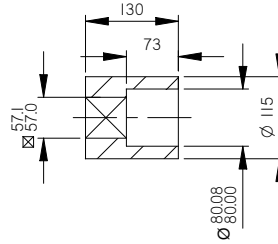

Vane Slot detail both ends

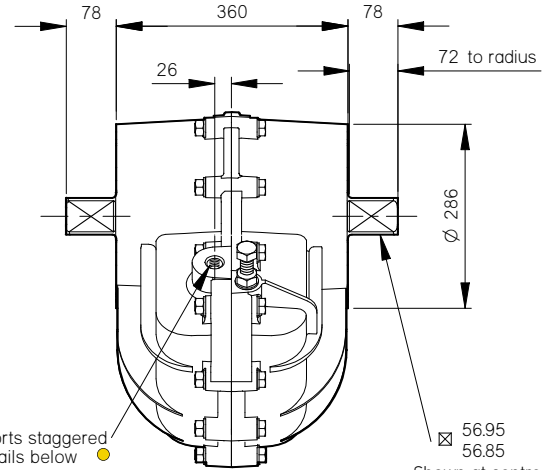
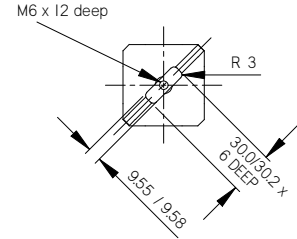

Specification

Output Torque

60000 lbf ins/6900 Nm
at 100 psi/7 bar

Angle of Travel (adjustable)

80° - 100°
(restricted travel
versions available)

Displaced Volume

1048 in³/17170 cm³

Finish

Epoxy stove enamel

Weight

157.4 lb/71.4 kg
(excluding coupling)

For further information
see General Specification
on page 50

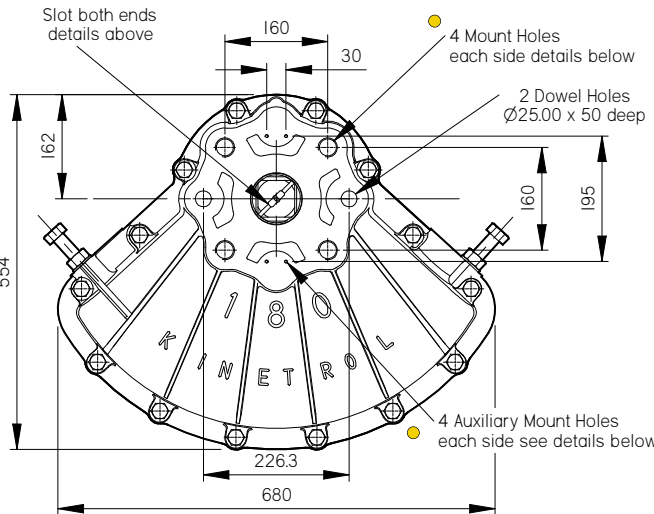

● Air Port/Mount Hole Details

Model	Air Ports	Mount Holes & Auxiliary Mount Holes
184-100	G ³ / ₄	M30 x 50 deep on 226.3 PCD
		M5 x 8 deep
187-100	3/4 NPT	1 1/8 UNC x 2.00" deep on 8.91" PCD
		10-24 UNC x 0.31" deep

Options

- Fail safe spring return units - clockwise or counter clockwise
- Limit switch boxes for open/close indication - various switches for hazardous areas
- AP pneumatic positioner - full range of options see pages 17/18
- EL electropneumatic positioner - full range of options see pages 15/16
- Code identification see page 53
- Torque outputs see pages 51/52
- See pages 44-46 for English dimensions and dimensions of spring options
- High temperature

Vane Slot detail both ends

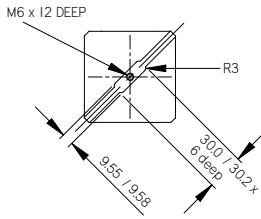

Standard Coupling
(supplied with actuator
weight 34 lbs/15.4 kg)

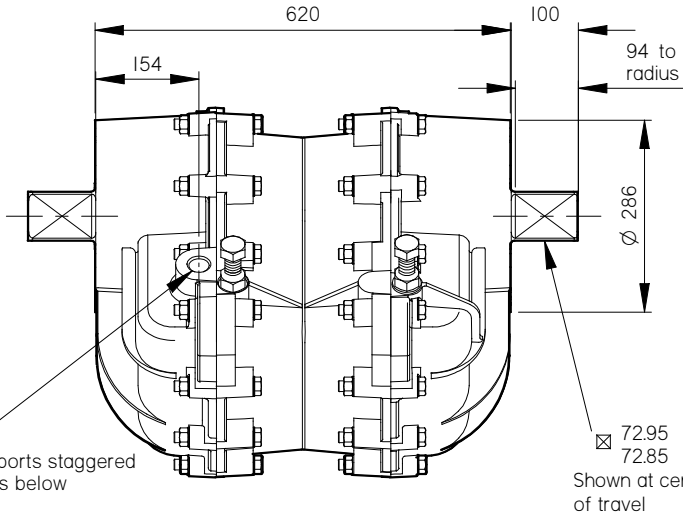
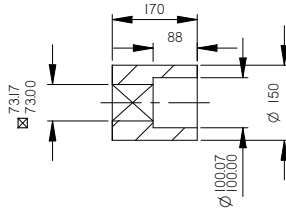

● 2 air ports staggered details below

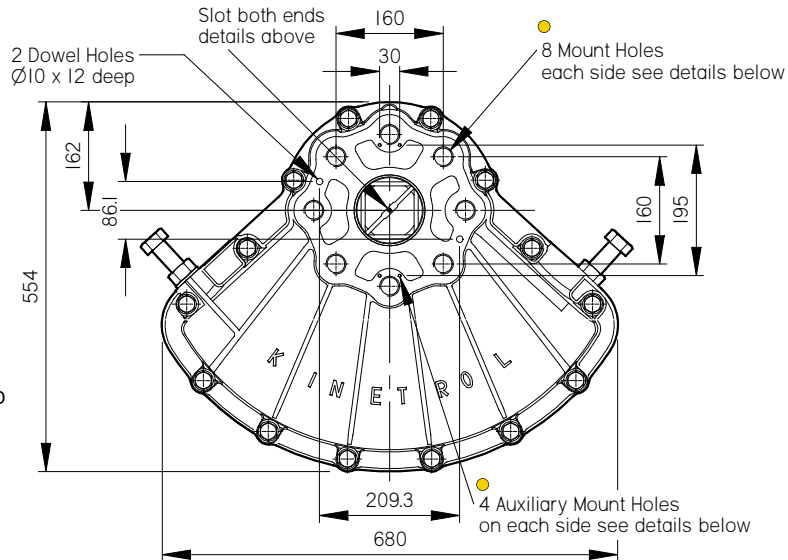

● Air Port/Mount Hole Details

Model	Air Ports	Mount Holes & Auxiliary Mount Holes
204-100	G1	M30 x 50 deep on 226 PCD M5 x 8 deep
207-100	1 NPT	1 1/8 UNC x 2.00" deep on 8.91" PCD 10-24 UNC x 0.31" deep

Options

- Fail safe spring return units - clockwise or counter clockwise
- Limit switch boxes for open/close indication - various switches for hazardous areas
- AP pneumatic positioner - full range of options see pages 17/18
- EL electropneumatic positioner - full range of options see pages 15/16
- Code identification see page 53
- Torque outputs see pages 51/52
- See pages 44-46 for English dimensions and dimensions of spring options

Specification

Output Torque

112000 lbf ins/12760 Nm
at 100 psi/7 bar

Angle of Travel (adjustable)

80° - 100°
(restricted travel versions available)

Displaced Volume

2034 in³/33350 cm³

Finish

Epoxy stove enamel

Weight

416.9 lb/195.6 kg
(excluding coupling)

For further information see General Specification on page 50.



Model 30



Specification

Output Torque

168000 lbf ins/19140 Nm
at 100 psi/7 bar

Angle of Travel (adjustable)

80° - 100°
(restricted travel
versions available)

Displaced Volume

3050 in³/50025 cm³

Finish

Epoxy stove enamel

Weight

601.91 lb/273 kg
(excluding coupling)

For further information
see General Specification
on page 50.



Standard Coupling
(supplied with actuator
weight 34 lbs/15.4 kg)

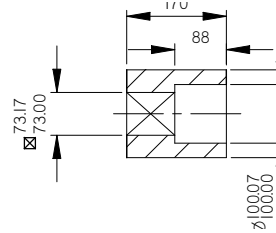

Vane Slot detail both ends

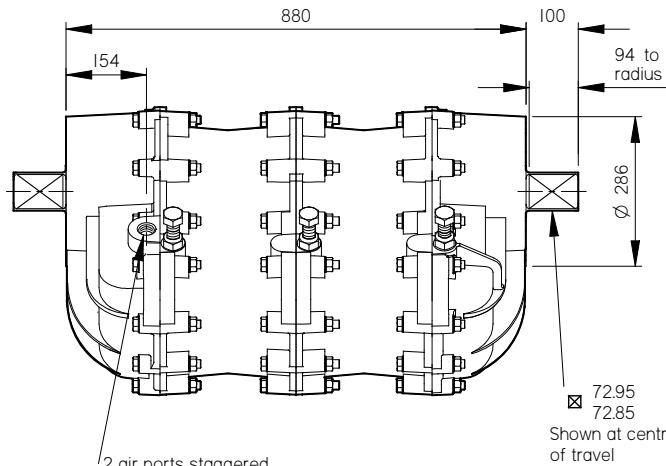
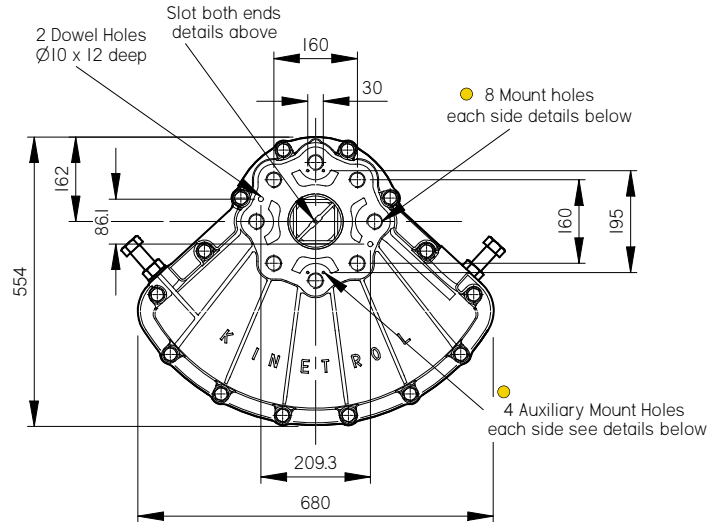
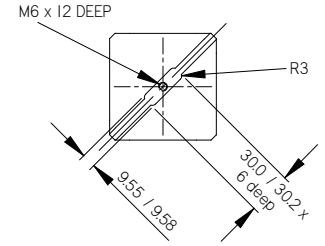

Air Ports/Mount Hole Details

Model	Air Ports	Mount Holes & Auxiliary Mount Holes
304-100	G1	M30 x 50 deep on 226 PCD M5 x 8 deep
307-100	1 NPT	1 1/8 UNC x 2.00" deep on 8.91" PCD 10-24 UNC x 0.31" deep

Options

- Fail safe spring return units - clockwise or counter clockwise
- EL electropneumatic positioner - full range of options see pages 15/16
- Limit switch boxes for open/close indication - various switches for all hazardous areas
- Code identification see page 53
- AP pneumatic positioner - full range of options see pages 17/18
- Torque outputs see pages 51/52
- See pages 44-46 for English dimensions and dimensions of spring options

Kinetrol declutchable geared overrides are available for models 05, 07, 09, 10, 12, 14 and 16, rated for the same torques as the actuators and fitted between the actuator and the load. The standard unit is supplied with the right hand handwheel option (see drawing below), whereby when the handwheel is moved in a clockwise direction the actuator moves in a counter clockwise direction. A left hand handwheel option is also available.



Dimensions

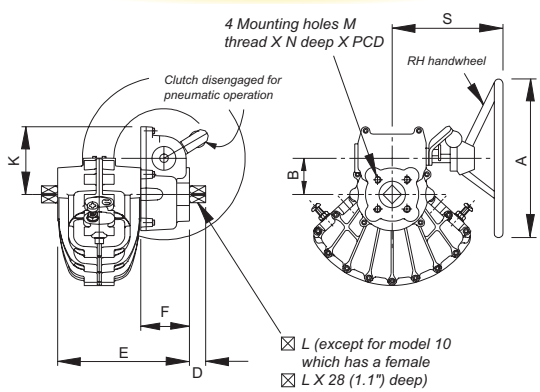

* N.B. Drawing is not representative of model 16 Gearbox. For full details contact Kinetrol

- Left hand handwheel option
- Declutch lever switch available
- Corrosion resistant - fully sealed to IP65

Metric Units

Actuator Model (ISO)	A mm	B mm	D mm	E mm	F mm	K mm	⊠ L mm	M	N mm	PCD mm	S mm	Wt kgs
05	300	67.8	13	170	103	127	9.5	M5	12	34.9	220	9.18
07	300	67.8	20	192	92	127	16.0	M8	16	50.9	220	11.20
09	300	67.8	26	218	92	127	19.0	M10	20	65.0	220	14.44
10	300	67.8	-	267	92	127	22.0	M10	20	102.0	220	17.50
12	300	67.8	31	248	92	127	25.0	M12	25	77.8	220	20.40
14	400	67.8	38	292	92	127	28.6	M16	28	98.8	250	32.06
16*	605	132.0	55	448	174	194	41.0	M16	28	200.0	276	69.80

English Units

Actuator Model (ANSI)	A Inch	B Inch	D Inch	E Inch	F Inch	K Inch	⊠ L Inch	M UNC	N Inch	PCD Inch	S Inch	Wt lbs
05	11.81	2.67	0.51	6.69	4.06	5.0	0.375	10-24	0.47	1.375	8.66	20.2
07	11.81	2.67	0.79	7.56	3.62	5.0	0.630	5/16	0.63	2.000	8.66	24.7
09	11.81	2.67	1.02	8.58	3.62	5.0	0.748	3/8	0.79	2.560	8.66	31.8
10	11.81	2.67	-	10.51	3.62	5.0	0.866	3/8	0.79	4.016	8.66	38.5
12	11.81	2.67	1.22	9.76	3.62	5.0	0.984	1/2	0.98	3.060	8.66	44.9
14	15.7	2.67	1.50	11.50	3.62	5.0	1.125	5/8	1.10	3.890	9.84	70.5
16*	23.8	5.20	2.17	17.64	6.85	7.64	1.614	5/8	1.10	7.874	10.87	154.0

Ordering Codes

Models 05 to 14:
(Standard right hand handwheel)

Models 05 to 14:
(Left hand handwheel)

Example for an 07 model:
074 K/Box (ISO Version)
077 K/Box (ANSI Version)

Example for an 07 model:
074 K/Box LH (ISO Version)
077 K/Box LH (ANSI Version)

* For model 16 replace 'K' with 'G'



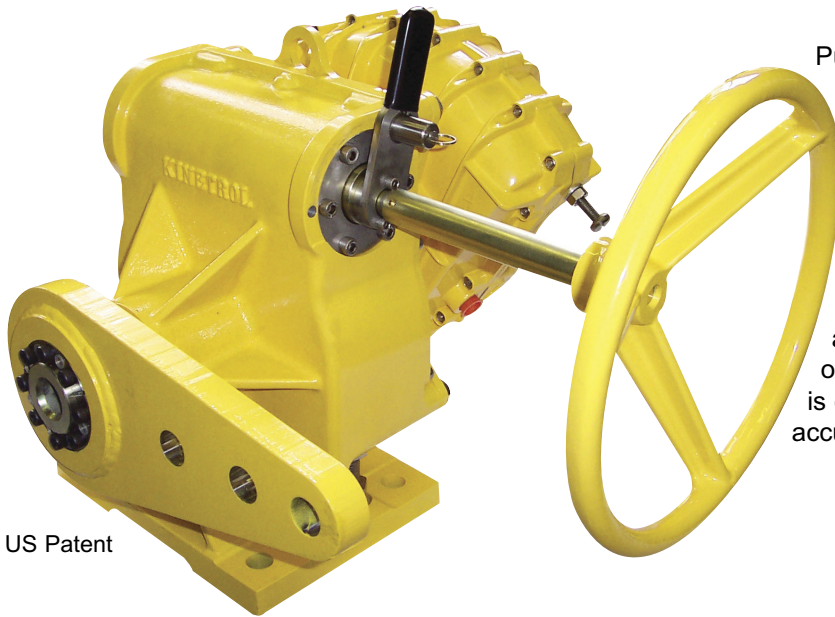

US Patent

Purpose designed, factory built and tested drives for air/gas flow control dampers on burner, heater, boiler and turbine systems in power plants, refineries and a wide range of industrial applications.

Combining the proven performance of Kinetrol's vane type actuator with an equally rugged integral manual override/mounting frame, the G3 drive is compact with unbeatable control, accuracy and cycle life.

LH handwheel position shown

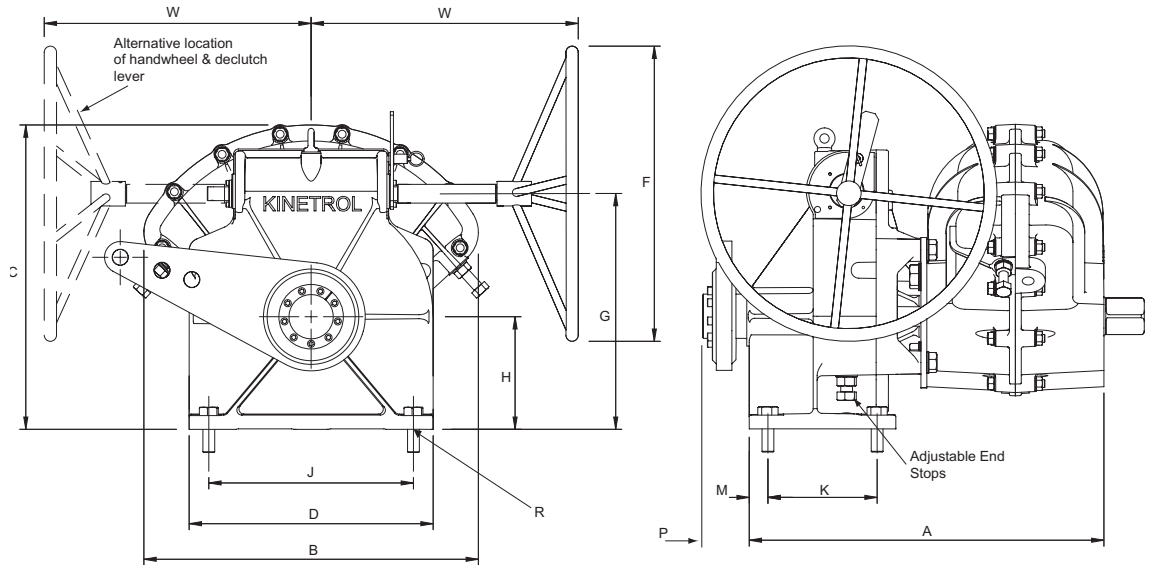

Principal Dimensions mm

Model	A	B	C	D	W*	F*	G	H	J	K	ØR	M	P	Weight †
144	410	381	390	275	276	300	300	165	216	152	21	25	70	46kg
164	495	525	470	275	305	400	300	165	216	152	21	25	70	51kg
184	721	680	620	496	406	760	479	229	416	222	27	38	94	141kg
204	981	680	620	496	508	600	479	229	416	222	27	38	94	158kg

Principal Dimensions inches

Model	A	B	C	D	W*	F*	G	H	J	K	ØR	M	P	Weight †
147	16.2	14.1	15.4	10.8	11.0	12.0	11.8	6.5	8.50	6.0	0.83	1.0	2.8	102lb
167	19.5	20.7	18.5	10.8	12.0	16.0	11.8	6.5	8.50	6.0	0.83	1.0	2.8	112lb
187	28.4	26.8	24.3	19.5	17.0	24.0	18.9	9.0	16.38	8.75	1.05	1.5	3.7	310lb
207	38.6	27.2	24.3	19.5	20.0	24.0	18.9	9.0	16.38	8.75	1.05	1.5	3.7	350lb

* Default dimensions, may change according to ordering code options.

† Listed weights exclude actuator

- Integral manual override
- Suitable for new installations or replacement of existing electric or pneumatic drives
- Available with same mounting foot print to replace existing floor mount drives
- Can result in lower energy costs resulting from accurate flow control
- Reduced operating costs due to long maintenance-free life (2 million operation warranty)
- Compact space saving design
- Quick and easy installation and set up
- Robust construction with durable epoxy finish
- Manual override usable with actuator removed



Options

- Double acting and spring fail-safe (open or closed)
- Modulating (3-15 psi and 4-20mA signal)
- Fail to low signal
- Lock in last position
- Limit switch remote position indication
- 4-20mA angle retransmission
- High visibility position indication
- Different sided/diameter handwheels and extensions
- Infinitely adjustable output levers to suit existing or new requirements



Ordering Codes

HANDWHEEL SIDE (SEE SKETCH)
L=LEFT
R=RIGHT

HANDWHEEL DIAMETER (F)

2=254mm - 10"
3=300mm - 12"
4=400mm - 16"
5=600mm - 24"
6=762mm - 30"

AVAILABLE ON MODELS:

14	16	18	20
E			
S	E		
E	S		
	E	E	S
		S	

OUTPUT LEVER THICKNESS (t)

1=3/8"
2=1/2"
3=5/8"
4=3/4"
5=7/8"
6=1"
7=1 1/8"
8=1 1/4"
9=1 1/2"

OPTIONAL LIMIT SWITCH BOX (TO INDICATE IF HANDWHEEL IS ENGAGED OR DISENGAGED)

OPTIONS:

- 0 = NO LIMIT SWITCH
- 1 = 2 x i/S PROX. SENSORS
- 2 = 2 x PNEUMATIC LS
- 4 = 2 x V3 MECH LS
- 5 = 2 x 20-260 Vac PROX.*
- 6 = 2 x 5-60 Vdc PROX.*
- 7 = 4 x V3 MECH LS

WHERE APPLICABLE:

- S = STANDARD
- Y = NO COST OPTION
- E = EXTRA COST OPTION
- ☐ = NOT AVAILABLE

INCLUDING D/A ACTUATOR:

- 144 = ISO BASIC D/A ACT
- 147 = ANSI BASIC D/A ACT
- 164 } ISO D/A ACT (FOR USE WITH OR WITHOUT POSITIONER)
- 184 }
- 204 }
- 167 } ANSI D/A ACT (FOR USE WITH OR WITHOUT POSITIONER)
- 187 }
- 207 }

V = HIGH TEMP
- = STD

POSITION MONITOR ON LS BOX:

- C=YES
- 0=NO

HOLE DIAMETER (d)

2=12.7mm - 1/2"
3=15.9mm - 5/8"
A=11/16"
4=19.1mm - 3/4"
5=22.2mm - 7/8"
6=25.4mm - 1"
7=28.6mm - 1 1/8"
8=31.8mm - 1 1/4"
9=38.1mm - 1 1/2"

HANDWHEEL OFFSET (W)

1= - 11"
2=305mm - 12"
3=430mm - 17"
4=508mm - 20"
5=600mm - 24"

AVAILABLE ON MODELS:

14	16	18	20
S			
	S		
E	E	S	
E	E	E	S
E	E	E	E

IF NECESSARY, FIT OPTIONAL EXTENSION TO ENSURE THAT HANDWHEEL IS AT A SAFE DISTANCE FROM MOVING OUTPUT LEVER.

LEVER HOLE PATTERN

No.	DISTANCE FROM CENTRE			AVAILABLE ON MODELS			
	C1	C2	C3	14	16	18	20
01	101.6mm - 4"	152.4mm - 6"	203.2mm - 8"	Y			
02	127mm - 5"	152.4mm - 6"	177.8mm - 7"	Y	Y		
03	127mm - 5"	198.1mm - 7.8"	254mm - 10"	Y	Y		
04	152.4mm - 6"	254mm - 10"	304.8mm - 12"	Y	Y	Y	
05	165.1mm - 6.5"	190.5mm - 7.5"	215.9mm - 8.5"	Y	Y	Y	
06	190.5mm - 7.5"	215.9mm - 8.5"	241.3mm - 9.5"	Y	Y	Y	
07	266.7mm - 10.5"	292.1mm - 11.5"	317.5mm - 12.5"	Y	Y	Y	Y
08	228.6mm - 9"	342.9mm - 13.5"	457.2mm - 18"	Y	Y	Y	Y
09	254mm - 10"	304.8mm - 12"	381mm - 15"	Y	Y	Y	Y
10	254mm - 10"	381mm - 15"	508mm - 20"	Y	Y	Y	Y
11	254mm - 10"	317.5mm - 12.5"	406.4mm - 16"	Y	Y	Y	Y
12	254mm - 10"	330.2mm - 13"	406.4mm - 16"	Y	Y	Y	Y
13	304.8mm - 12"	406.4mm - 16"	444.5mm - 17.5"	Y	Y	Y	Y
14	317.5mm - 12.5"	363.2mm - 14.3"	406.4mm - 16"	Y	Y	Y	Y
15	147.3mm - 5.8"	279.4mm - 11"	304.8mm - 12"	Y	Y	Y	Y
16	152.4mm - 6"	190.5mm - 7.5"	228.6mm - 9"	Y	Y		
17	101.6mm - 4"	-	304.8mm - 12"	Y			
18	-	-	127mm - 5"	Y	Y		
19	-	-	203.2mm - 8"	Y	Y	Y	

* Not available with ATEX approval

For torque outputs see pages 51/52



For more information see KF-535



Kinetrol Interfacing Options

Kinetrol is continually responding to the evolving requirements of the industry for interfacing arrangements that satisfy user needs and conform to industry standards and we offer a range of designs that enable our equipment to be effectively and economically mounted.

Kinetrol can supply direct mounting limit switch boxes, positioners and other control modules that eliminate the costs associated with interfacing hardware and provide compact assemblies. Recent actuator topworks changes have enhanced the interchangeability of the control modules.

Various female drive spring fail-safe and hand spring unit options are available to facilitate direct mounting to valves with topworks details that conform to the ISO 5211 standard.

The innovative, patented, ISO adaptor is available for Kinetrol actuator models 03-09 and provides a versatile and robust mounting option. The adaptor is suitable for use with a wide range of ISO topworks valves.

Our larger actuator models are manufactured with a drive slot and insert option, designed to interface with ancillary drives that comply with the VDI/VDE 3485 norm.

For compact and space-saving solenoid valve mounting, Kinetrol offers a NAMUR interface adaptor which allows the air supply to be ported directly to the actuator body, thereby eliminating the need for any external piping.

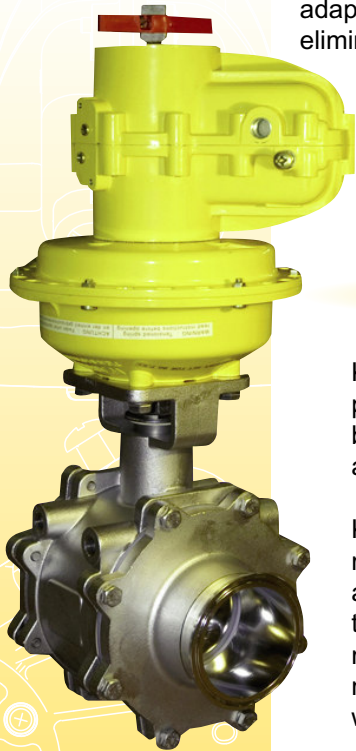

Kinetrol's Valve Automation Services

Kinetrol can assemble automated on/off and modulating valve packages using its robust part-turn actuators and extensive range of modular control units. We can select/supply ball, butterfly and plug valves from across the industry or mount actuators to free-issued valves.

Kinetrol has 50 years experience in valve automation and is renowned for its build quality. Thousands of mount kit designs are readily available and new arrangements can be designed to meet specific customer needs. Customised packages are regularly engineered to suit difficult applications and meet the most demanding specifications. We can provide assemblies which are fully compliant with ATEX, NEC or IEC requirements.

Kinetrol's broad engineering capabilities, combined with its rigorous quality assurance and testing procedures ensure that customers receive effective solutions that are built and documented to the highest standards.

For more information regarding our valve automation services please contact Kinetrol.



ISO Flange Male Spring Return Actuator Dimensions

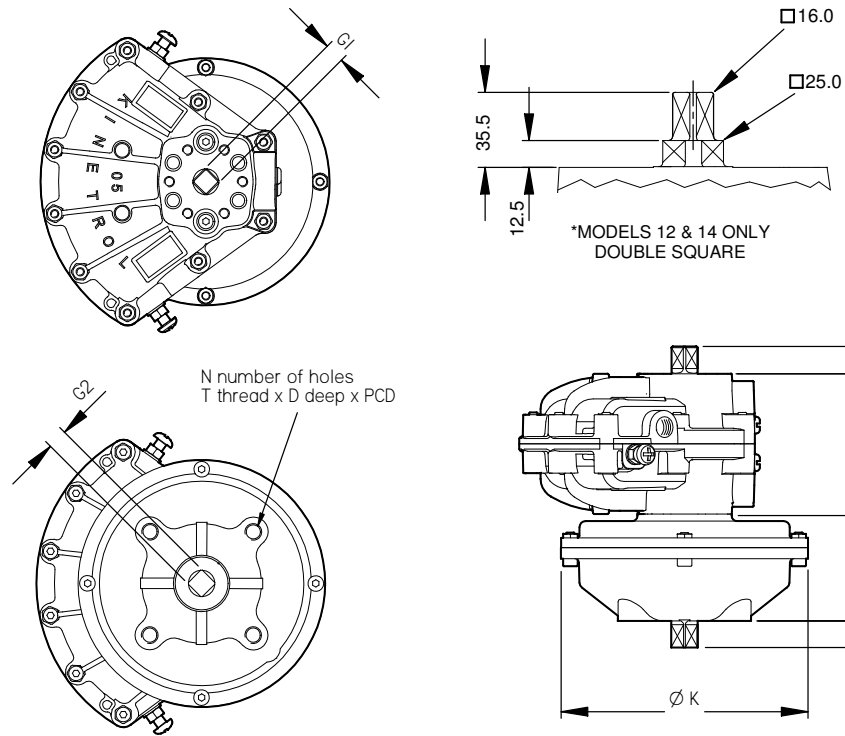

Metric Units

Actuator** Model	L mm	H mm	ØK mm	⊠ G1 mm	⊠ G2 mm	S1 mm	S2 mm	N No.	T ISO	D mm	PCD mm	Wt Kg
024-120	90.0	40.0	73.0	8.0	8.0	10.0	10.0	4	M4	8.0	25.5	0.84
034-120	107.0	47.0	107.0	9.0	9.0	12.0	12.0	4	M5	10.0	31.1	2.08
054-120	117.0	50.0	118.0	9.5	9.5	13.0	13.0	6	M5	8.0	34.9	2.63
074-120	182.0	82.0	152.0	16.0	16.0	20.0	20.0	4	M8	16.0	50.9	7.26
094-120	218.0	92.0	200.0	16.0	19.0	20.0	26.0	4	M10	20.0	65.0	12.15
104-120	285.0	112.0	206.0	16.0	22.0	35.5	26.0	4	M10	16.0	102.0	22.00
124-120	293.0	136.0	258.0	16.0*	25.0	35.5	31.0	4	M12	22.0	77.8	27.95
144-120-4900	417.0	217.0	258.0	16.0*	28.6	35.5	38.0	4	M16	28.5	98.8	51.81
144-120	374.0	174.0	394.0	16.0*	28.6	35.5	38.0	4	M16	28.5	98.8	71.25
144-120-5000	337.0	137.0	258.0	16.0*	28.6	35.5	38.0	4	M16	28.5	98.8	38.18
164-120-6100	450.0	176.0	394.0	41.0	41.0	55.0	55.0	4	M24	32.0	152.7	75.00
164-120	485.5	211.5	524.0	41.0	41.0	55.0	55.0	4	M24	38.0	152.7	123.0
184-120-7000	571.5	211.5	524.0	57.0	57.0	78.0	78.0	4	M30	50.0	226.3	161.0
184-120	671.5	311.5	524.0	57.0	57.0	78.0	78.0	4	M30	50.0	226.3	240.0
204-120-7200	931.5	311.5	524.0	73.0	73.0	100.0	100.0	8	M30	50.0	226.3	350.0
204-120-7300	1031.5	411.5	524.0	73.0	73.0	100.0	100.0	8	M30	50.0	226.3	408.0
204-120	1131.5	511.5	524.0	73.0	73.0	100.0	100.0	8	M30	50.0	226.3	479.0
304-120-7600	1293.0	411.5	524.0	73.0	73.0	100.0	100.0	8	M30	50.0	226.3	524.0
304-120-7700	1393.0	511.5	524.0	73.0	73.0	100.0	100.0	8	M30	50.0	226.3	606.0
304-120-7800	1493.0	611.5	524.0	73.0	73.0	100.0	100.0	8	M30	50.0	226.3	688.0
304-120	1593.0	711.5	524.0	73.0	73.0	100.0	100.0	8	M30	50.0	226.3	770.0

English Units

Actuator** Model	L inch	H inch	ØK inch	⊠ G1 inch	⊠ G2 inch	S1 inch	S2 inch	N No.	T UNC	D inch	PCD inch	Wt lb
027-120	3.54	1.58	2.87	0.315	0.315	0.39	0.39	4	8-32	0.31	1.00	1.85
037-120	4.21	1.85	4.21	0.354	0.354	0.47	0.47	4	10-24	0.39	1.225	4.58
057-120	4.61	1.97	4.25	0.375	0.375	0.51	0.51	6	10-24	0.31	1.375	5.80
077-120	7.17	3.23	6.00	0.630	0.630	0.79	0.79	4	5/16-18	0.63	2.00	16.00
097-120	8.58	3.62	7.90	0.630	0.748	0.79	1.02	4	3/8-16	0.79	2.56	26.80
107-120	11.22	4.41	8.11	0.630	0.866	0.79	1.02	4	3/8-16	0.63	4.02	48.50
127-120	11.54	5.35	10.16	0.630*	0.984	1.40	1.22	4	1/2-13	0.87	3.06	61.62
147-120-4900	16.43	8.54	10.16	0.630*	1.125	1.40	1.50	4	5/8-11	1.12	3.89	113.98
147-120	14.72	6.85	15.50	0.630*	1.125	1.40	1.50	4	5/8-11	1.13	3.89	157.0
147-120-5000	13.27	5.40	10.16	0.630*	1.125	1.40	1.50	4	5/8-11	1.13	3.89	84.19
167-120-6100	17.72	6.93	15.50	1.614	1.614	2.17	2.17	4	7/8-9	1.26	6.01	165.0
167-120	19.11	8.33	20.63	1.614	1.614	2.17	2.17	4	7/8-9	1.50	6.01	272.0
187-120-7000	22.50	8.33	20.63	2.244	2.244	3.07	3.07	4	1 1/8-7	1.97	8.91	356.0
187-120	26.44	12.26	20.63	2.244	2.244	3.07	3.07	4	1 1/8-7	1.97	8.91	530.0
207-120-7200	36.67	12.26	20.63	2.874	2.874	3.94	3.94	8	1 1/8-7	1.97	8.91	773.0
207-120-7300	40.61	16.20	20.63	2.874	2.874	3.94	3.94	8	1 1/8-7	1.97	8.91	901.0
207-120	44.55	20.14	20.63	2.874	2.874	3.94	3.94	8	1 1/8-7	1.97	8.91	1058.0
307-120-7600	50.91	16.20	20.63	2.874	2.874	3.94	3.94	8	1 1/8-7	1.97	8.91	1158.0
307-120-7700	54.84	20.14	20.63	2.874	2.874	3.94	3.94	8	1 1/8-7	1.97	8.91	1339.0
307-120-7800	58.78	24.07	20.63	2.874	2.874	3.94	3.94	8	1 1/8-7	1.97	8.91	1520.0
307-120	62.72	28.01	20.63	2.874	2.874	3.94	3.94	8	1 1/8-7	1.97	8.91	1701.0

** Clockwise (120) and counterclockwise (130) units have identical dimensions



ISO Flange Female Spring Return Actuator Dimensions

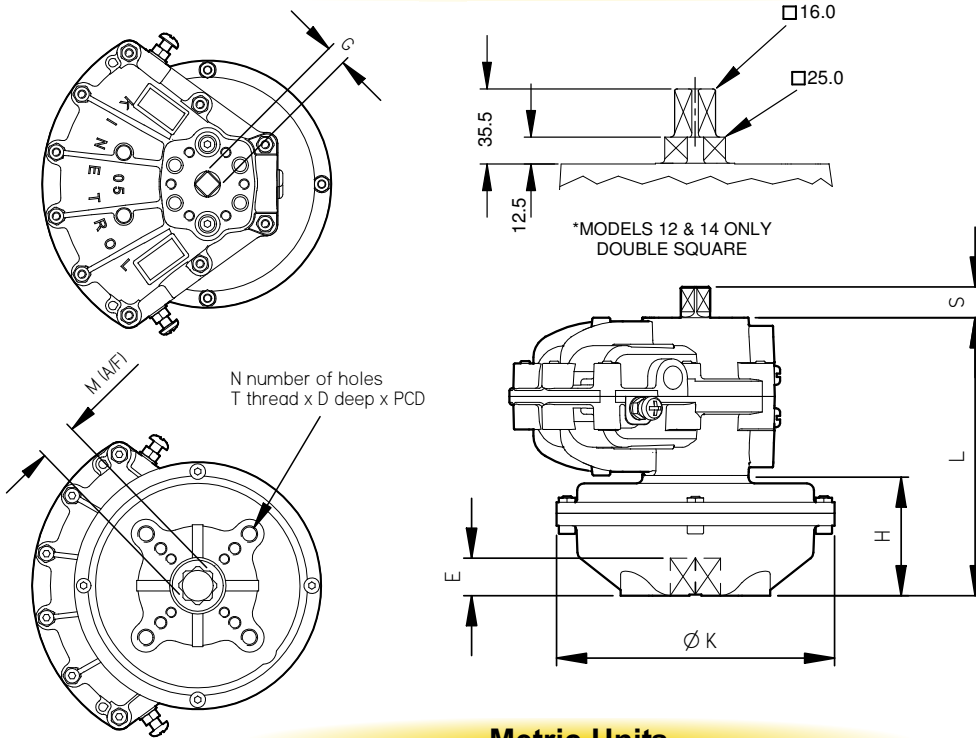

Spring Return Actuator Dimensions

Metric Units

Actuator** Model	ISO Flange No.	L mm	H mm	ØK mm	M mm	S mm	⊠ G mm	E mm	N No.	T ISO	D mm	PCD mm
033F120	F03/F05	102	42	107	11	12	9.0	12	4	M5/M6	8/10	36/50
033F180	F04	102	42	107	11	12	9.0	12	4	M5	10	42
053F120	F03/F05/F07	117	50	118	14	13	9.5	16	4	M5/M6/M8	10/12/13	36/50/
053F180	F04	117	50	118	14	13	9.5	16	4	M5	10	42
073F120-4000	F03/F05/F07	150	50	118	14	20	16.0	16	4	M5/M6/M8	10/12/13	36/50
073F120	F05/F07	182	82	152	17	20	16.0	19	4	M6/M8	10/13	50/70
093F120-4200	F05/F07	208	82	152	17	20	16.0	19	4	M6/M8	10/13	50/70
093F120	F07/F10	218	92	200	22	20	16.0	24	4	M8/M10	13/16	70/102
103F120-5800	F07/F10	265	92	200	22	20	16.0	24	4	M8/M10	13/16	70/102
103F120	F10	285	112	206	22	20	16.0	25	4	M10	16	102
123F120-4300	F10	248	92	200	22	35.5	16.0*	24	4	M10	16	102
123F120-4400	F10	340	184	200	22	35.5	16.0*	24	4	M10	16	102
123F120	F10	293	136	258	22	35.5	16.0*	25	4	M10	16	102
123F180	F12	293	136	258	22	35.5	16.0*	25	4	M12	20	125
143F120-4900	F12	417	217	258	27	35.5	16.0*	29	4	M12	20	125
143F120-5000	F12	337	136	258	22	35.5	16.0*	25	4	M12	20	125
163F120***	F14	486	212	524	36	55	41.0	38	4	M16	24	140
183F120-7000***	F16	572	212	524	46	78	57.0	48	4	M20	30	165
183F120***	F16	672	312	524	46	78	57.0	48	4	M20	30	165
203F120-7200***	F25	932	312	524	55	100	73.0	57	8	M16	24	254
203F120-7300***	F25	1032	412	524	55	100	73.0	57	8	M16	24	254
203F120***	F25	1132	512	524	55	100	73.0	57	8	M16	24	254

English Units

Actuator** Model	ISO Flange No.	L inch	H inch	ØK inch	M inch	S inch	⊠ G inch	E inch	N No.	T UNC	D inch	PCD inch
037F120	F03/F05	4.02	1.65	4.21	0.433	0.47	0.354	0.47	4	10-24 1/4	0.31/0.39	1.41/1.97
037F180	F04	4.02	1.65	4.21	0.433	0.47	0.354	0.47	4	10-24	0.39	1.65
057F120	F03/F05/F07	4.61	1.97	4.65	0.551	0.51	0.374	0.63	4	10-24 1/4 5/16	0.39/0.47/0.51	1.42/1.97/2.76
057F180	F04	4.61	1.97	4.65	0.551	0.51	0.374	0.63	4	10-24	0.39	1.65
077F120-4000	F03/F05/F07	5.91	1.97	4.65	0.551	0.79	0.630	0.63	4	10-24 1/4 5/16	0.39/0.47/0.51	1.42/1.97/2.76
077F120	F05/F07	7.17	3.23	5.98	0.669	0.79	0.630	0.75	4	1/4 5/16	0.39	1.97/2.76
097F120-4200	F05/F07	8.19	3.23	5.98	0.669	0.79	0.630	0.75	4	1/4 5/16	0.39/0.51	1.97/2.76
097F120	F07/F10	8.58	3.62	7.87	0.866	0.79	0.630	0.94	4	5/16 3/8	0.51/0.63	2.76/4.01
107F120-5800	F07/F10	10.43	3.62	7.87	0.866	0.79	0.630	0.94	4	5/16 3/8	0.51/0.63	2.76/4.01
107F120	F10	11.22	4.41	8.11	0.866	0.79	0.630	0.98	4	3/8	0.63	4.02
127F120-4300	F10	9.76	3.62	7.87	0.866	1.40	0.630*	0.94	4	3/8	0.63	4.02
127F120-4400	F10	13.39	7.24	7.87	0.866	1.40	0.630*	0.94	4	3/8	0.63	4.02
127F120	F10	11.54	5.35	10.16	0.866	1.40	0.630*	0.98	4	3/8	0.63	4.02
127F180	F12	11.54	5.35	10.16	0.866	1.40	0.630*	0.98	4	1/2	0.79	4.92
147F120-4900	F12	16.42	8.54	10.16	1.063	1.40	0.630*	1.14	4	1/2	0.79	4.92
147F120-5000	F12	13.27	5.35	10.16	0.866	1.40	0.630*	0.98	4	1/2	0.79	4.92
167F120***	F14	19.13	8.35	20.63	1.417	2.17	1.614	1.50	4	5/8	0.94	5.51
187F120-7000***	F16	22.52	8.35	20.63	1.811	3.07	2.244	1.89	4	3/4	1.18	6.50
187F120***	F16	26.46	12.28	20.63	1.811	3.07	2.244	1.89	4	3/4	1.18	6.50
207F120-7200***	F25	36.70	12.28	20.63	2.165	3.94	2.874	2.24	8	5/8	0.94	10.00
207F120-7300***	F25	40.63	16.22	20.63	2.165	3.94	2.874	2.24	8	5/8	0.94	10.00
207F120***	F25	44.57	20.16	20.63	2.165	3.94	2.874	2.24	8	5/8	0.94	10.00

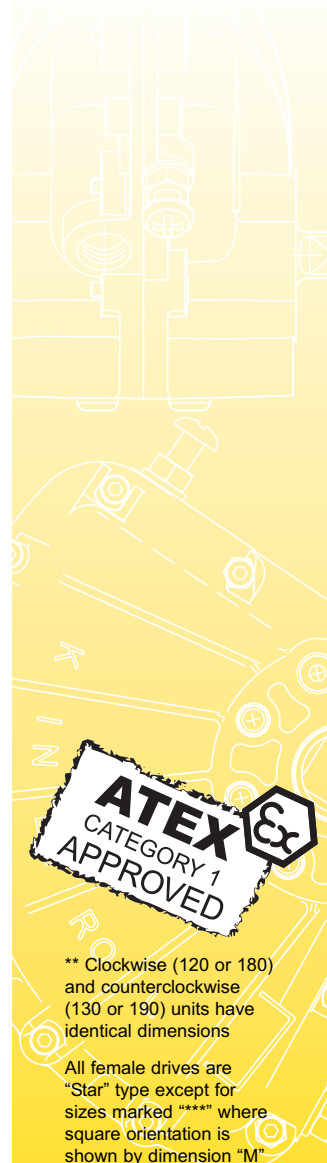

** Clockwise (120 or 180) and counterclockwise (130 or 190) units have identical dimensions

All female drives are "Star" type except for sizes marked "****" where square orientation is shown by dimension "M"

AP Positioner Dimensions

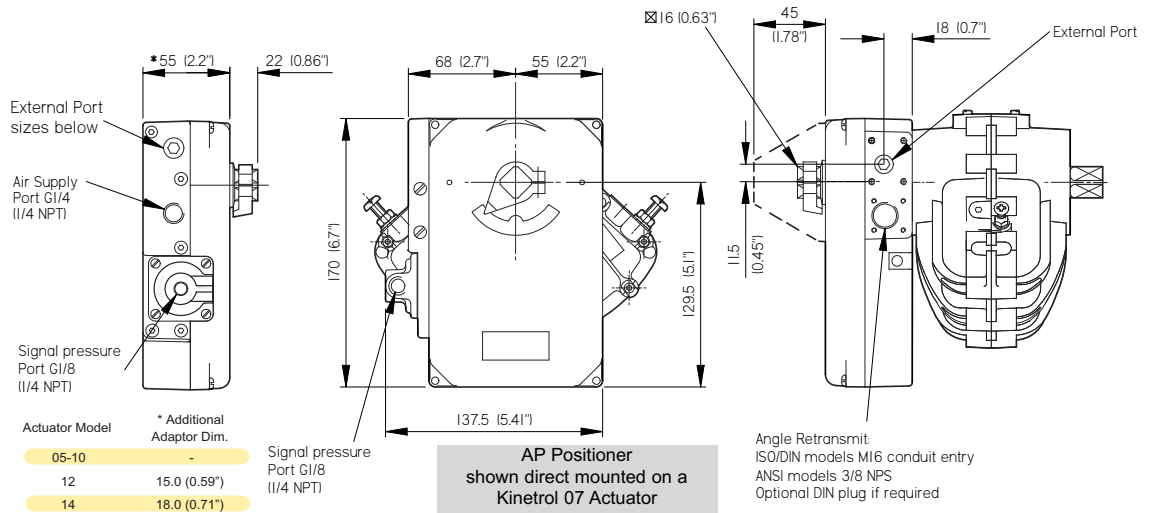

Namur Discrete Version

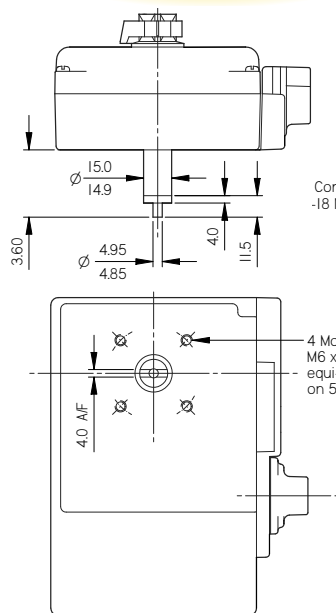

Non-Hazardous I/P Version

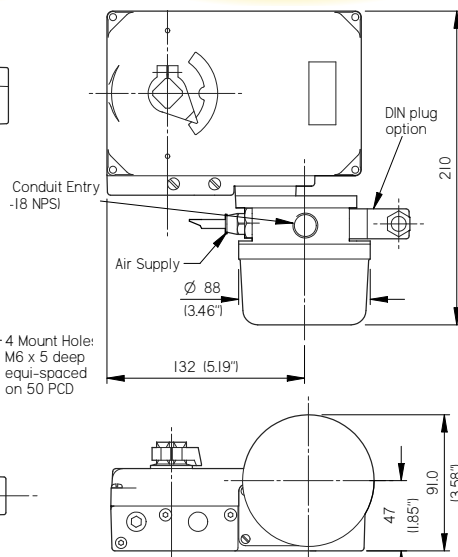

Kinetrol Discrete/ High Flow Version

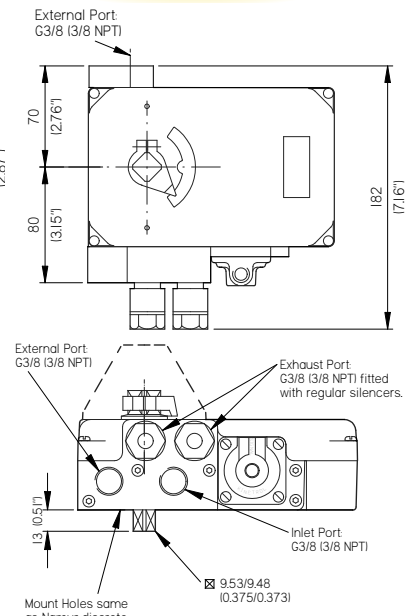

Explosion Proof I/P Version

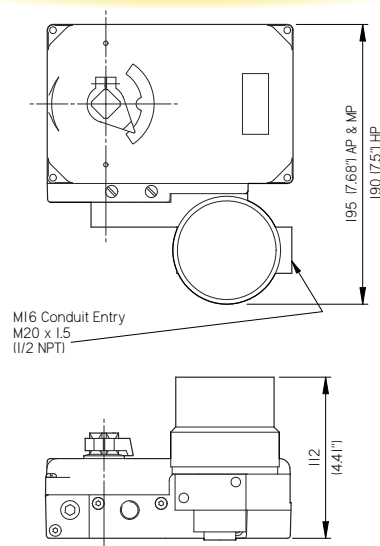

Switch Box Version

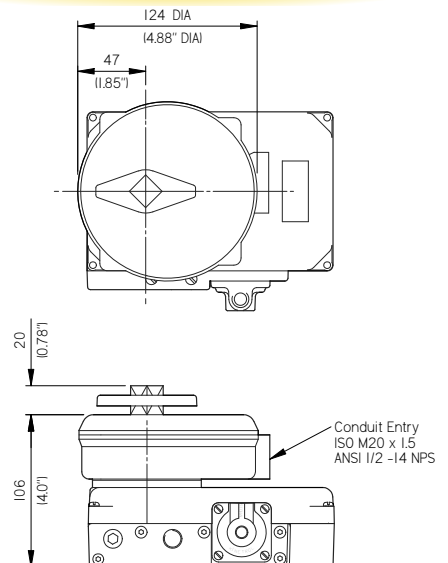

Where drawing information is not given - it is the same as the direct mount version

EL Positioner Dimensions

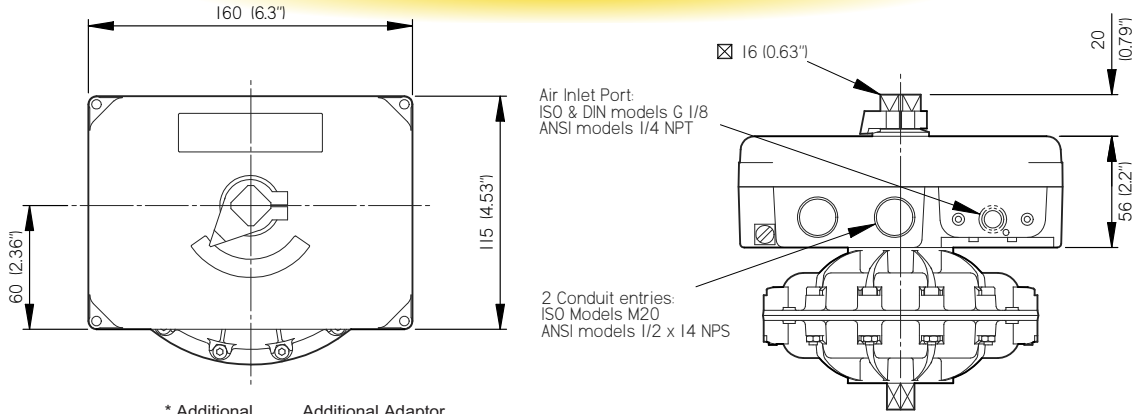

Actuator Model	* Additional Adaptor Dim.	Additional Adaptor Weight
12	15.0 (0.59")	0.65 kg/1.4 lbs
14	18.0 (0.71")	0.65 kg/1.4 lbs

Direct Mount Version

EL Positioner shown direct mounted on a Kinetrol 05 actuator

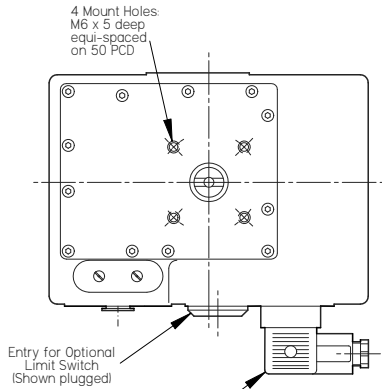
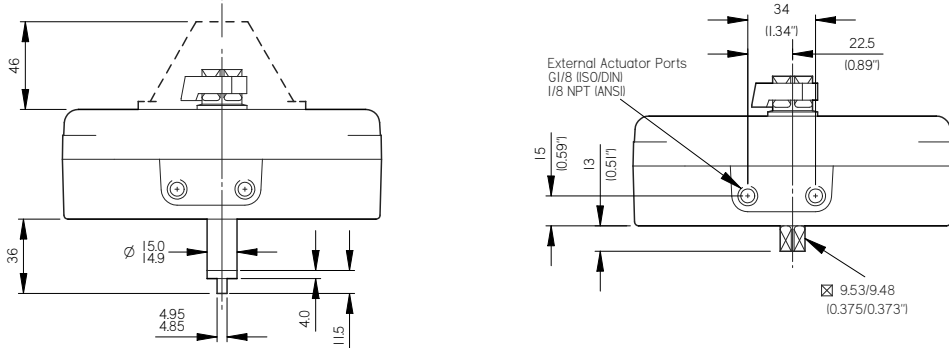

Namur Discrete Version

Din Plug options - shown 90° out of true position ISO/DIN models cable gland 18 to 10 mm dial ANSI models 1/2 NPT cable entry (for use with flexible conduit).

Where drawing information is not given - it is the same for both versions

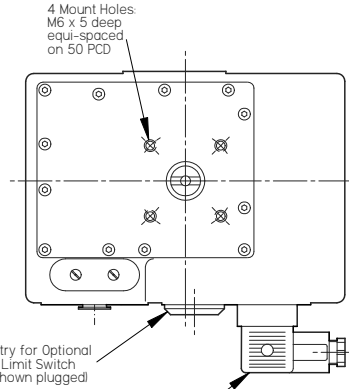

Kinetrol Discrete Version

Din Plug options - shown 90° out of true position ISO/DIN models cable gland 18 to 10 mm dial ANSI models 1/2 NPT cable entry (for use with flexible conduit).

P3 3-Stop Pneumatic Positioner Dimensions

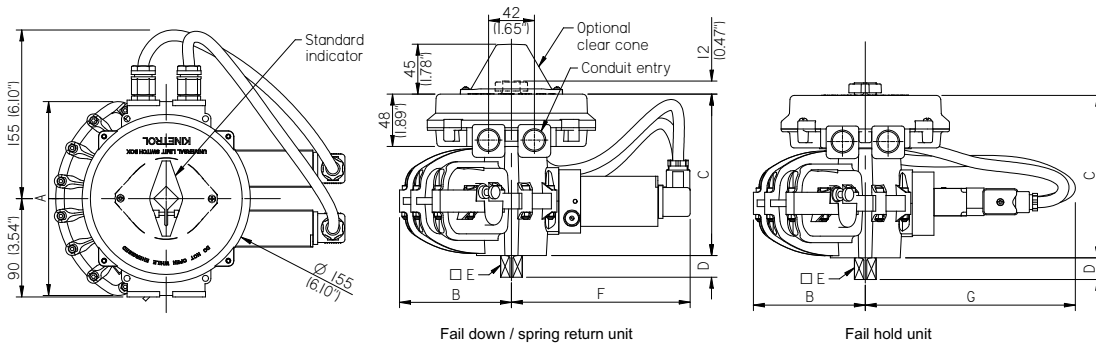

MODEL	A	B	C	D	E	F	G
05	136.0 (5.35")	78.4 (3.09")	115.0 (4.53")	13.0 (0.51")	9.5 (0.375")	155 (6.10")	184 (7.25")
07	178.0 (7.01")	102.6 (4.04")	148.0 (5.83")	20.0 (0.79")	16.0 (0.630")	164 (6.46")	193 (7.60")
08	179.0 (7.05")	113.6 (4.47")	147.0 (5.79")	19.0 (0.75")	14.3 (0.562")	162 (6.38")	191 (7.52")
09	227.0 (8.94")	132.3 (5.21")	174.0 (6.85")	26.0 (1.02")	19.0 (0.748")	175 (6.89")	204 (8.03")
10	230.0 (9.06")	130.5 (5.14")	223.0 (8.78")	25.5 (1.00")	22.0* (0.870")	179 (7.03")	207 (8.17")
12	294.0 (11.57")	171.0 (6.73")	204.0 (8.03")	31.0 (1.22")	25.0 (0.984")	189 (7.44")	218 (8.58")
14	380.0 (14.96")	222.0 (8.74")	248.0 (9.76")	38.0 (1.50")	28.6 (1.125")	205 (8.07")	234 (9.21")

* Model 10 DIN (F10) female drive

Universal Limit Switch Box Dimensions

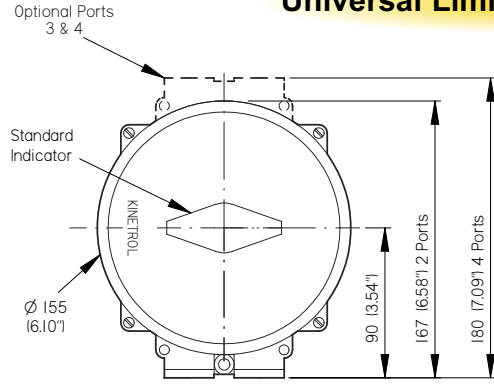

Standard Orientation Of Unit

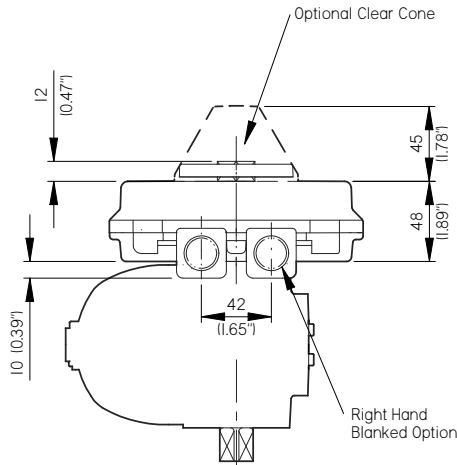

Direct Mount Option

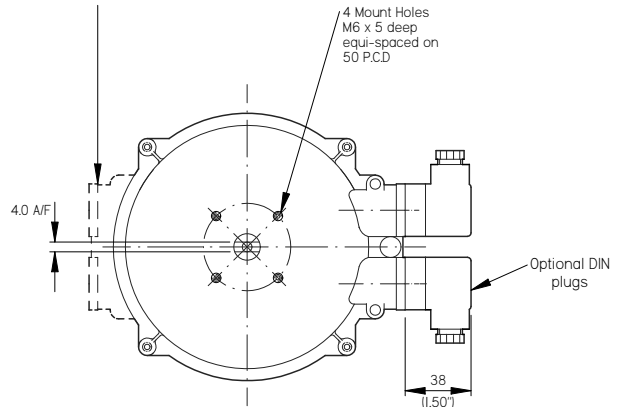
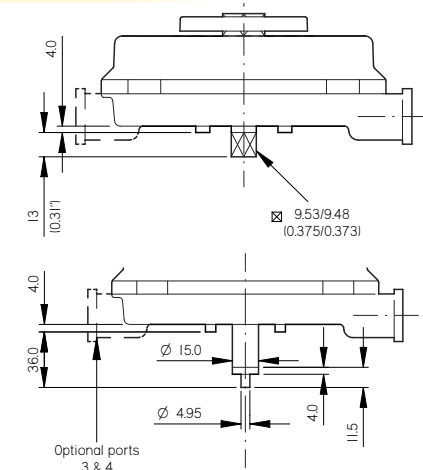

Kinetrol & Namur Discrete Mount Option

Explosion Proof Limit Switch Box Dimensions

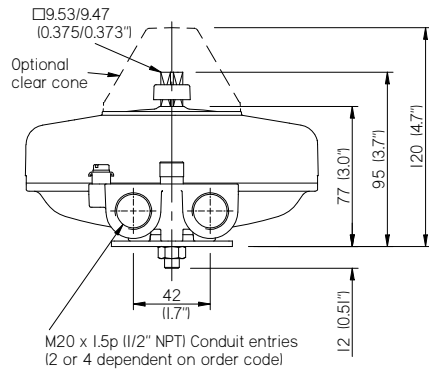

Kinetrol Close Mount Option

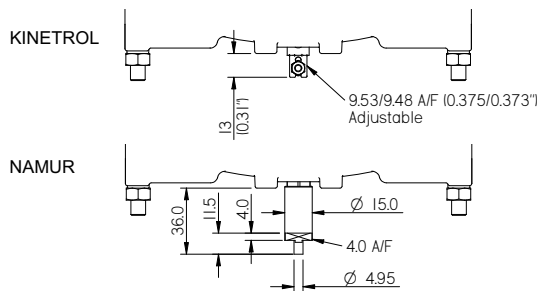
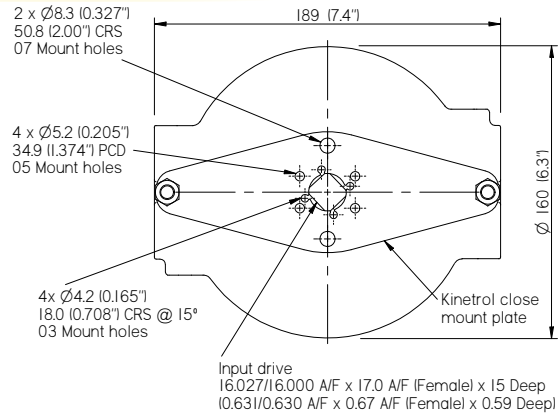

Discrete Mount Option

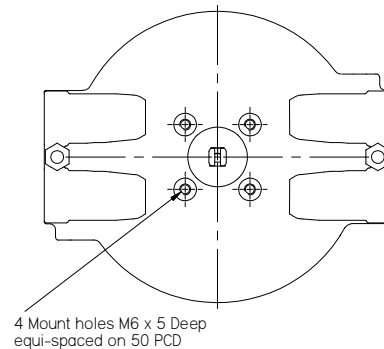

Actuator General Specification

Casing: Pressure die cast ZL 16 zinc alloy except models 09/12/14/16/18/20 & 30 (aluminium LM24 or 25).

Vane & output shaft: Models OMO, 01, 02, 03 and 05 stainless steel. Models 07 to 30 SG iron, zinc plated.

Shaft bushes: PTFE coated bronze.

Seals: Moulded polyurethane. High and low temperature seals also available contact Kinetrol.

Seal expanders: Stainless spring steel.

Couplings: Weldable mild steel, zinc plated.

Working temperature range: -20°C (-5°F) to 80°C (175°F). Up to 100°C (212°F) with high temperature seals and higher temperatures with special equipment - contact Kinetrol for details. Down to -40°C (-40°F), include option 'L' at end of actuator coding.

Maximum recommended working pressure: 100 psi (7 bar)

Maximum overload pressure: 150 psi (10 bar)

Spring Fail-Safe Electric Actuators

Kinetrol's double acting and spring return electrohydraulic actuators are designed for use in locations without a compressed air supply. A hydraulic pump delivers pressurised oil to a Kinetrol quarter-turn actuator, providing a double acting torque output up to 1220 Nm/10800 lbf in.

In the case of single acting units, a Kinetrol spring return and fail-open solenoid valve produce a positive fail-safe action.

A 100% rated pump motor and pressure release valve provide stall protection.

This, together with the units capacity for up to 3000 starts per hour, make it also ideal for both high cycle double acting or modulating applications.

Various AC and DC voltage builds are available and options include auxiliary limit switches and/or a 4-20 mA transducer for position feedback.

See leaflet KF-503 for further information.

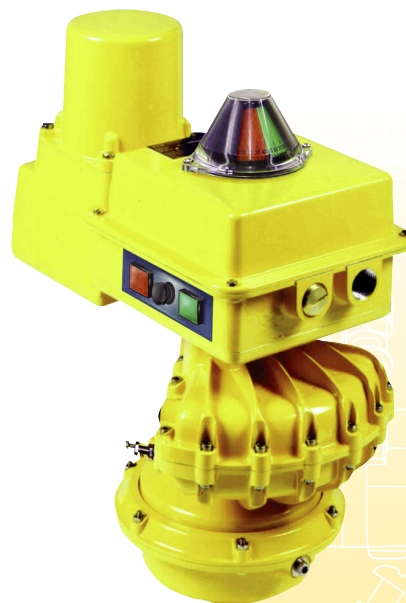

Rotary Dampers

Kinetrol's range of fluid dashpots are used to steady drives, decelerate motion and damp vibration. Standard designs include fixed and adjustable rate devices for limited angle or continuous rotation damping in one or both directions of travel.

Applications for these robust, industrial dampers include the precise control of:

- tension on wire/paper/film/textile handling equipment
- the rate of descent of curtains, shutters etc.
- oscillations of pendulums, gimbals etc.
- jerk on camera & simulator systems
- vibration on transfer machinery.

See catalogue KF-72 for more information. If required, Kinetrol can engineer special designs to meet customers specifications.

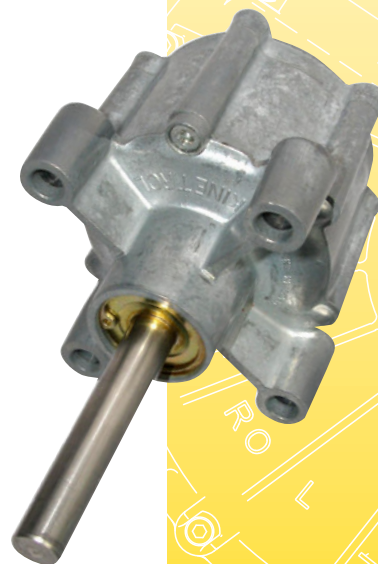

Double Acting Torque Outputs - Metric Units Nm

Actuator Model	pressure (bar)											
	1.5	2.0	2.5	3.0	3.5	4.0	4.5	5.0	5.5	6.0	6.5	7.0
OMO - 100	0.1	0.2	0.25	0.35	0.4	0.5	0.55	0.6	0.7	0.75	0.85	0.9
01 - 100	1.1	1.6	2.1	2.6	3.0	3.5	4.0	4.5	5.1	5.6	6.1	6.7
02 - 100	1.8	2.7	3.6	4.6	5.5	6.4	7.3	8.2	9.2	10.2	11.1	12.1
03 - 100	3.9	5.8	7.6	9.6	11.5	13.4	15.4	17.4	19.3	21.3	23.2	25.3
05 - 100	9.0	12.5	16.5	20	24.0	27.5	31.5	35.0	39.0	43.0	46.5	50.5
07 - 100	22.0	30.5	39.5	48.5	57.5	66.5	76.0	85.5	95.0	105.0	114.0	124.0
08 - 100	31	44	57	69	82	95	108	121	134	147	160	173
09 - 100	46	64	83	102	121	140	159	179	199	220	241	261
10 - 100	80	111	141	172	202	232	263	294	325	355	385	416
12 - 100	103	147	190	232	275	319	360	403	446	490	532	575
14 - 100	265	360	460	560	660	760	870	975	1080	1180	1280	1375
16 - 100	640	860	1090	1310	1530	1750	1980	2200	2420	2650	2870	3100
18 - 100	1250	1750	2250	2750	3250	3750	4300	4850	5400	5950	6400	6900
20 - 100	2480	3440	4400	5310	6290	7230	8160	9090	10020	10960	11890	12760
30 - 100	3720	5160	6600	7695	9435	10845	12240	13635	15030	16440	17835	19140

Spring Return Torque Outputs - Metric Units Nm

Actuator Model	Position of air OR spring return stroke	pressure setting (bar)											
		1.7	2.0	2.4	2.8	3.1	3.5	3.8	4.1	4.5	4.8	5.2	5.5
01-120	Start						1.5		1.7		1.9		2.3
	Finish						0.9		1.1		1.5		1.8
02-120	Start						3.0	3.4	3.6	3.8	4.2	4.4	4.7
	Finish						1.4	1.7	2.0	2.4	2.8	3.3	3.7
03-120-5600	Start	2.8	3.4	4.1	4.8	5.3	5.7						
	Finish	2.1	2.8	3.5	4.2	4.8	5.1	5.1	5.1	5.1	5.1	5.1	5.1
03-120	Start						6.3	6.9	7.5	8.1	8.9	9.5	10.3
	Finish						4.1	4.7	5.5	6.4	7.2	7.8	8.7
05-120	Start						13.0	14.1	15.3	16.4	18.1	19.2	20.9
	Finish						8.5	9.6	11.3	13.0	14.7	15.8	17.5
07-120-4000	Start	9.0	11.9	15.3	18.6	22.0							
	Finish	5.1	8.5	11.9	15.3	18.0	18.0	18.0	18.0	18.0	18.0	18.0	18.0
07-120	Start						30.5	33.9	37.3	40.7	43.5	46.9	50.8
	Finish						19.8	23.7	27.1	30.5	34.4	38.4	42.4
08-120-4100	Start	18.6	23.7	27.1	31.1	35.0	39.5	44.1	48.0	52.5	56.5		
	Finish	7.9	13.6	16.9	20.9	26.0	30.5	35.0	39.0	43.5	47.5	47.5	47.5
08-120	Start								56.5	61.0	65.5	70.6	
	Finish								45.2	50.3	54.8	59.9	
09-120-4200	Start	26.0	31.6	37.3	44.1	50.8							
	Finish	14.7	21.5	28.2	35.0	41.8	41.8	41.8	41.8	41.8	41.8	41.8	41.8
09-120	Start						61.0	67.8	74.6	81.9	89.3	96.6	104.0
	Finish						50.3	56.5	63.8	71.2	79.1	86.4	93.8
10-120-5800	Start	56.0	65.0	77.0	89.0	97.0	108.0						
	Finish	41.8	52.0	64.0	77.2	86.9	100.0	100.0	100.0	100.0	100.0	100.0	100.0
10-120	Start						107.0	115.5	124.0	136.0	145.0	155.9	164.0
	Finish						78.0	90.0	102.0	114.6	124.0	134.9	143.0
12-120-4300	Start	54.0	68.9	83.6									
	Finish	42.9	57.6	72.3	72.3	72.3	72.3	72.3	72.3	72.3	72.3	72.3	72.3
12-120-4400	Start			89.3	103.0	117.0	132.0	147.0	161.0	176.0	191.0		
	Finish			66.1	80.2	94.9	110.0	124.0	139.0	154.0	168.0	168.0	168.0
	Start						145.0	160.0	176.0	191.0	206.0	221.0	238.0
12-120	Finish						111.0	127.0	142.0	158.0	174.0	189.0	204.0
	Start	192.0	220.0	249.0	288.0	322.0	356.0	390.0	424.0	469.0	497.0	529.0	529.0
14-120-4900	Finish	119.0	158.0	186.0	220.0	254.0	288.0	322.0	356.0	390.0	418.0	447.0	447.0
	Start						374.0	408.0	442.0	479.0	517.0	554.0	588.0
14-120	Finish						249.0	290.0	330.0	367.0	406.0	443.0	478.0
	Start	172.0	208.0	237.0									
16-120-6100	Finish	140.0	174.0	198.0	198.0	198.0	198.0	198.0	198.0	198.0	198.0	198.0	198.0
	Start	359.0	428.0	497.0									
16-120-6000	Finish	245.0	333.0	421.0	421.0	421.0	421.0	421.0	421.0	421.0	421.0	421.0	421.0
	Start			514.0	583.0	652.0	722.0						
16-120	Finish			404.0	492.0	580.0	668.0	668.0	668.0	668.0	668.0	668.0	668.0
	Start						864.0	939.0	1004.0	1097.0	1165.0	1256.0	1321.0
18-120-7000	Finish						576.0	660.0	742.0	832.0	906.0	1002.0	1081.0
	Start	807.0	970.0	1182.0	1260.0								
18-120	Finish	484.0	736.0	967.0	1040.0	1040.0	1040.0	1040.0	1040.0	1040.0	1040.0	1040.0	1040.0
	Start				1457.0	1637.0	1875.0	2053.0	2206.0	2426.0	2585.0	2800.0	2954.0
20-120-7200	Finish				874.0	1036.0	1250.0	1441.0	1630.0	1840.0	2011.0	2234.0	2417.0
	Start	1621.0	1940.0	2325.0	2692.0								
20-120-7300	Finish	1025.0	1362.0	1763.0	2203.0	2203.0	2203.0	2203.0	2203.0	2203.0	2203.0	2203.0	2203.0
	Start				2788.0	3072.0	3471.0	3739.0	4023.0				
20-120	Finish				1958.0	2271.0	2632.0	2983.0	3291.0	3291.0	3291.0	3291.0	3291.0
	Start								4121.0	4514.0	4798.0	5181.0	5456.0
30-120-7600	Finish								3046.0	3423.0	3732.0	4133.0	4464.0
	Start	2433.0	2878.0	3466.0	4038.0								
30-120-7700	Finish	1622.0	2127.0	2696.0	3304.0	3304.0	3304.0	3304.0	3304.0	3304.0	3304.0	3304.0	3304.0
	Start				4112.0	4554.0	5113.0						
30-120-7800	Finish				3118.0	3542.0	4183.0	4183.0	4183.0	4183.0	4183.0	4183.0	4183.0
	Start						5237.0	5676.0	6072.0	6648.0			
30-120	Finish						3871.0	4304.0	4844.0	5440.0	5440.0	5440.0	5440.0
	Start								6771.0	7179.0	7772.0	8184.0	
30-120	Finish								5134.0	5598.0	6200.0	6696.0	

Torque outputs identical for counter-clockwise models . *Italic* figures apply to spring end torque only - air end torque will be greater.

Double Acting Torque Outputs - English Units lbf ins

Actuator Model	Pressure (psi)								
	20	30	40	50	60	70	80	90	100
OMO - 100	1	2	3	3.5	4.5	5	6	7	8
01 - 100	9	15	21	26	32	39	45	51	58
02 - 100	14	25	36	48	59	70	82	93	105
03 - 100	29	53	77	101	124	148	173	196	220
05 - 100	70	116	160	205	250	300	346	393	440
07 - 100	175	280	390	500	610	730	850	960	1080
08 - 100	250	405	560	710	870	1030	1190	1350	1510
09 - 100	360	590	820	1050	1280	1530	1780	2020	2280
10 - 100	640	1020	1390	1760	2130	2500	2880	3250	3625
12 - 100	830	1350	1870	2400	2900	3440	3970	4480	5000
14 - 100	2150	3350	4550	5800	7000	8300	9600	10800	12000
16 - 100	5200	7900	10600	13400	16100	18800	21600	24300	27000
18 - 100	10000	16100	22200	28300	34500	41300	48000	54500	60000
20 - 100	20000	32000	43000	54500	66000	78000	89000	100500	112000
30 - 100	30000	48000	64500	81750	99000	117000	133500	150750	168000

Spring Return Torque Outputs - English Units lbf ins

Actuator Model	Position of air OR spring return stroke	Pressure setting (psi)											
		20	30	35	40	45	50	55	60	65	70	75	80
01-120	Start						13		15		17		20
	Finish						8		10		13		16
02-120	Start						27	30	32	34	37	39	42
	Finish						12	15	18	21	25	29	33
03-120-5600	Start	25	30	36	42	47	50						
	Finish	19	25	31	37	42	45	45	45	45	45	45	45
03-120	Start						56	61	66	71	79	84	91
	Finish						37	41	49	56	64	69	77
05-120	Start						115	125	135	145	160	170	185
	Finish						75	85	100	115	130	140	155
07-120-4000	Start	80	105	135	165	195							
	Finish	45	75	105	135	160	160	160	160	160	160	160	160
07-120	Start						270	300	330	360	385	415	450
	Finish						175	210	240	270	305	340	375
08-120-4100	Start	165	210	240	275	310	350	390	425	465	500		
	Finish	70	120	150	185	230	270	310	345	385	420	420	420
08-120	Start								500	540	580	625	
	Finish								400	445	485	530	
09-120-4200	Start	230	280	330	390	450							
	Finish	130	190	250	310	370	370	370	370	370	370	370	370
09-120	Start						540	600	660	725	790	855	925
	Finish						445	500	565	630	700	765	830
10-120-5800	Start	500	587	683	760	886	953						
	Finish	366	472	568	645	780	847	847	847	847	847	847	847
10-120	Start						950	1025	1100	1190	1280	1365	1450
	Finish						690	795	900	1000	1100	1185	1270
12-120-4300	Start	480	610	740									
	Finish	380	510	640	640	640	640	640	640	640	640	640	640
12-120-4400	Start			790	910	1040	1170	1300	1430	1560	1690		
	Finish			585	710	840	970	1100	1230	1360	1490	1490	1490
12-120	Start						1280	1415	1555	1690	1825	1960	2110
	Finish						985	1125	1260	1400	1540	1670	1810
14-120-4900	Start	1700	1950	2200	2550	2850	3150	3450	3750	4150	4400	4680	4680
	Finish	1050	1400	1650	1950	2250	2550	2850	3150	3450	3700	3960	3960
14-120	Start						3310	3610	3915	4240	4580	4900	5200
	Finish						2205	2570	2920	3250	3595	3920	4230
14-120-5000	Start	1520	1840	2100									
	Finish	1240	1540	1750	1750	1750	1750	1750	1750	1750	1750	1750	1750
16-120-6100	Start	3178	3790	4401									
	Finish	2172	2950	3729	3729	3729	3729	3729	3729	3729	3729	3729	3729
16-120-6000	Start		4551	5163	5774	6386							
	Finish		3579	4357	5136	5914	5914	5914	5914	5914	5914	5914	5914
16-120	Start						7646	8310	8885	9708	10310	11116	11691
	Finish						5098	5841	6567	7363	8018	8868	9567
18-120-7000	Start	7142	8585	10461	11151								
	Finish	4283	6514	8558	9204	9204	9204	9204	9204	9204	9204	9204	9204
18-120	Start				12894	14487	16594	18169	19523	21470	22877	24780	26143
	Finish				7735	9169	11063	12753	14426	16284	17797	19771	21390
20-120-7200	Start	14346	17169	20576	23824								
	Finish	9071	12054	15603	19497	19497	19497	19497	19497	19497	19497	19497	19497
20-120-7300	Start				24674	27187	30718	33090	35604				
	Finish				17328	20098	23293	26400	29125	29125	29125	29125	29125
20-120	Start								36471	39949	42462	45852	48286
	Finish								26957	30294	33028	36577	39506
30-120-7600	Start	16797	25470	30674	35736								
	Finish	9394	18824	23860	29240	29240	29240	29240	29240	29240	29240	29240	29240
30-120-7700	Start				36391	40303	45250						
	Finish				27594	31347	37020	37020	37020	37020	37020	37020	37020
30-120-7800	Start						46347	50233	53737	58835			
	Finish						34258	38090	42869	48144	48144	48144	48144
30-120	Start									59923	63693	68782	72428
	Finish									45436	49542	54870	59260

Torque outputs identical for counter-clockwise models . *Italic* figures apply to spring end torque only - air end torque will be greater.



Kinetrol Actuators and Add-On Control Units

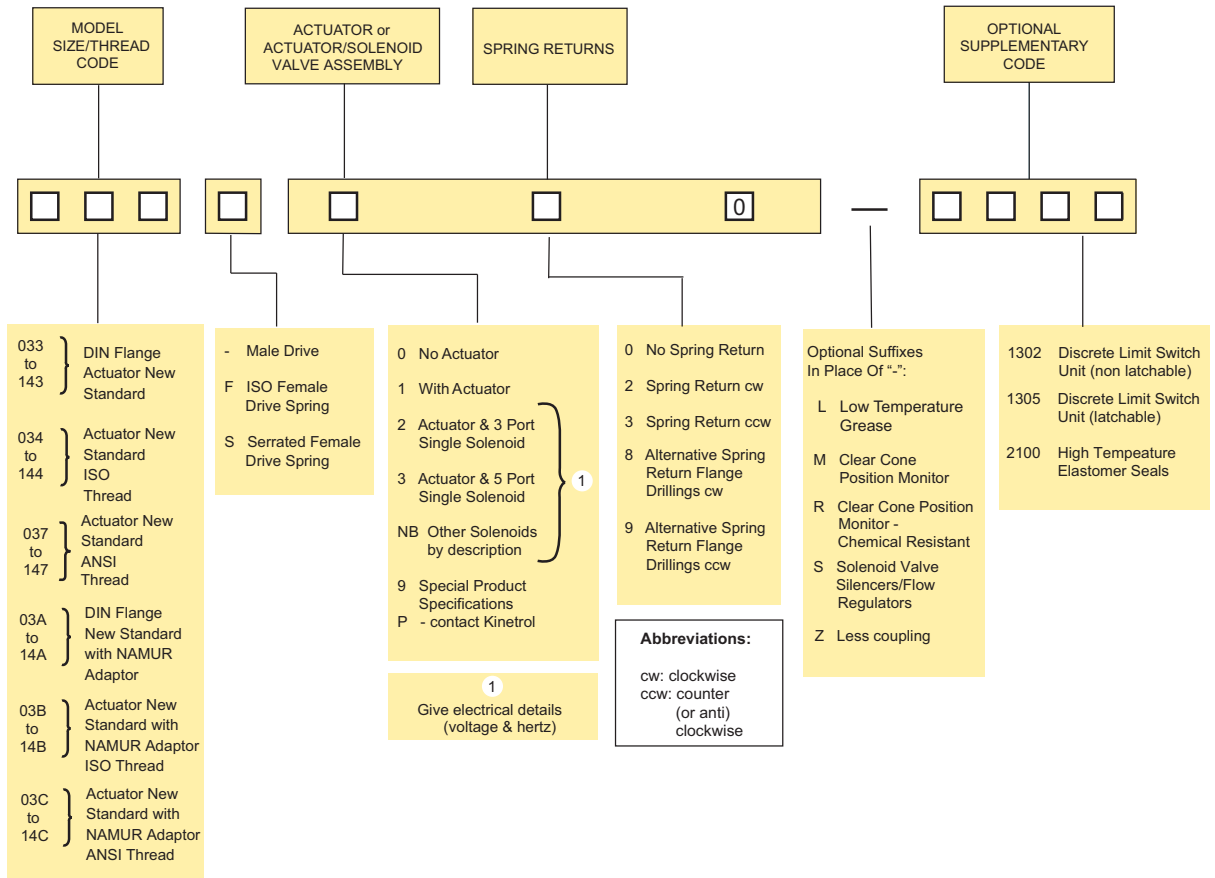

EXAMPLES

- A: 054-100 Double acting actuator (ISO threads) no optional supplementary items
- B: 054-120M A + spring return (fail-safe cw) + Clear Cone monitor
- C: 057-100 Double acting actuator (ANSI threads)
- D: 144-130-4900 140 actuator (ISO threads) + spring return fail-safe ccw (2 x 120 springs)
- E: 053F100 Double acting actuator with ISO adaptor

- Low Pressure Air Application ordering codes - see page 4
- Female Drive Spring Unit ordering codes - see page 5
- Universal Limit Switch ordering codes - see page 8
- Explosion Proof Limit Switch Box ordering codes - see page 12
- P3 3-Stop Positioner ordering codes - see page 14
- EL Positioner ordering codes - see page 16
- AP Positioner & I/P Controller ordering codes - see page 18
- ISO Adaptor ordering codes - see page 20
- Manual & Fire Fail-Safe Unit ordering codes - see page 21
- 180° Actuator ordering codes - see page 23
- Geared Manual Override ordering codes - see page 40
- Damper Drive ordering codes - see page 42

Catalogue Index

	Pages
Kinetrol Vane Actuators	1
Modular 'Add On' Control Units	2
Fail-Safe Spring Return Units	3/4
Female Drive Spring Units	5
Clear Cone Monitors	6
Solenoid Valves	6
Universal Limit Switch Box	7/8
AS Interface Bus Communications	9/10
Explosion Proof Limit Switch Box	11/12
P3 3-Stop Positioner	13/14
EL Electropneumatic Positioner	15/16
AP Positioner	17/18
I/P Controller	19
ISO Adaptor	20
Manual & Fire Fail-Safe Spring Units	21/22
180 Degree Pneumatic Actuators	23/24
Actuator Models 0M0 - 30	25-39
Geared Manual Overrides	40
G3 Damper Drives	41/42
Interface Options & Valve Mounting Service	43
Actuator Dimensions	44
Spring Return Actuator Dimensions	45/46
AP Positioner Dimensions	47
EL & P3 3-Stop Positioner Dimensions	48
Universal & Explosion Proof Limit Switch Box Dimensions	49
Actuator General Specification	50
Other Products	50
Metric Torque Outputs	51
English Torque Outputs	52
Actuator Ordering Codes	53



Worldwide Distribution

Austria

Dietrich Schwabe GmbH
Einsteinstrasse 26
D-64859 Eppertshausen
Deutschland
Tel - (49) 6071 922290
Fax - (49) 6071 9222911
email - info@schwabe-sra.de

Australia

Norgren Pty Ltd
33 Corporate South Ave
Rowville 3178
Victoria
Tel - 1800 NORGREN (667473)
Fax - 03 9213 0880
email - enquiry@norgren.com.au

Belgium

NV Prodim SA
Rue G. Van Laethemstraat 67
B-1140
Brussels
Tel - 02 726 3300
Fax - 02 726 3633
email - info@prodim.biz

Canada

Gosco Valves
1272 Speers Road (Unit 4)
Oakville
Ontario L6L 5T9
Tel - 905 825 2627
Fax - 905 825 4051
email - sales@goscovalves.com

China

Shanghai Kinetrol
Control Equipment Co. Ltd.
4209 Shendu Road
Shanghai
201112 PRC
Tel - 21 5431 2366
Fax - 21 5431 2399
email - kinetrolchina@sohu.com

Denmark

Armotec A/S
Mjølnersvej 4-8
DK-2600 Glostrup
Tel - 4696 0000
Fax - 4696 0001
email - armatec@armatec.dk

Finland

Aseko Oy
Tinankuja 3
FIN-02430 Masala
Tel - 10 4001012
Fax - 10 4001200
email - info@aseko.fi

France

Kinetrol Sarl, Actigone 3 - BP1028
74966 MEYTHET cedex
Tel - 0450 22 19 26
Fax - 0450 22 31 54
email - kinetrol@kinetrol.fr

Germany

Dietrich Schwabe GmbH
Einsteinstrasse 26, D-64859
Eppertshausen
Tel - 6071 922290
Fax - 6071 9222911
email - info@schwabe-sra.de

Hong Kong

Norgren Ltd
6/F Benson Tower
74 Hung To Road
Kwun Tong, Kowloon
Tel - 2492 7608
Fax - 2498 5878
email - enquiries@norgren.com.hk

Hungary

Tech-Con Hungaria Kft
1133 Budapest XIII. District
Véső u. 9-11
Tel - 1412 4167
Fax - 1412 4171
email - tech-con@tech-con.hu

India

Peregrine Technologies Pvt Ltd
Unit 138, Building 1
New Sonal Link Industrial Estate
Link Road, Malad (W), Mumbai 400 064
Tel - 22 2882 1497
Fax - 22 2844 9430
email - sales@peregrinetechnologies.org

Indonesia

Matco Asia PTE Ltd
19 Kian Teck Crescent
Singapore 628885
Tel - 65 6261 0359
Fax - 65 6264 1677
email - sales@matcoasia.com.sg

Iran

Master Arya Co.
No. 49, 4th Floor
Soleyman Khater St.
Motahhari Ave., Tehran
Tel - 8834 6854
Fax - 8834 6855
email - info@masterarya.com

Israel

Baccara Automation Control
Kvutzat Geva 18-915
Tel - 4653 5960
Fax - 4653 1445
email - baccara@netvision.net.il

Italy

Bellkin S.r.l.
Via Torricelli 51
20038-Seregno-MI
Tel - 0362 330269
Fax - 0362 327069
email - info@bellkin.com

Japan

HKS Japan Ltd
Promity Fuchinobe Building
1-9-15 Kanumadai
Sagamihara
Kanagawa 229-0033
Tel - 042 751 9131
Fax - 042 751 9700
email - info@hksjapan.co.jp

Korea

Dollidam FA Co. Ltd
1555-10, Samsan-Dong
Nam-Gu
Ulsan-City
Tel - 052-254-2816
Fax - 052-254-2817
email - topvalve@hitel.net

Malaysia

Matco Asia PTE Ltd
19 Kian Teck Crescent
Singapore 628885
Tel - 65 6261 0359
Fax - 65 6264 1677
email - sales@matcoasia.com.sg

Netherlands

Delan BV
Satellietbaan 20 F
Postbox 218
2180 AE Hillegom
Tel - 0252 528870
Fax - 0252 528470
email - info@delan.nl

New Zealand

Norgren Ltd
3-5 Walls Road
Penrose
Auckland 1061
Tel - 0800 NORGREN (667473)
Fax - 09 526 3399
email - enquiry@norgren.co.nz

Poland

Dietrich Schwabe GmbH
Einsteinstrasse 26
D-64859 Eppertshausen
Deutschland
Tel - (49) 6071 922290
Fax - (49) 6071 9222911
email - info@schwabe-sra.de

Portugal

Kinetrol S.L.
C/Salmeron, 250
08226-Terrassa
Barcelona
Tel - 93 7862496
Fax - 93 7851368
email - kinetrol@kinetrol.es

Singapore

Matco Asia PTE Ltd
19 Kian Teck Crescent
Singapore 628885
Tel - 6261 0359
Fax - 6264 1677
email - sales@matcoasia.com.sg

South Africa

Rotatech cc.
Granite Drive 1
Kya Sands Business Park
Kya Sand Ext. 48,2169
PO Box 2052, Cresta 2118
Tel - 11 708 6860
Fax - 11 708 6866
email - sales@rotatech.co.za

Spain

Kinetrol S.L.
C/Salmeron, 250
08226-Terrassa
Barcelona
Tel - 93 7862496
Fax - 93 7851368
email - kinetrol@kinetrol.es

Sweden

Alnab Armatur AB
Ogardesvagen 4B
433 86 Partille
Tel - 31 449450
Fax - 31 442455
email - alnab@alnab.se

Switzerland

Dietrich Schwabe GmbH
Einsteinstrasse 26
D-64859 Eppertshausen
Deutschland
Tel - (49) 6071 922290
Fax - (49) 6071 9222911
email - info@schwabe-sra.de

Taiwan

Controltek International Co. Ltd
4th Fl. No. 20 Alley 18
Lane 478, Rui-Guang Road
Nei-Hu, Taipei 114
Tel - 2 26277671
Fax - 2 26277673
email - kontek@ms14.hinet.net

Thailand

Interteca United
(Asia) Co. Ltd
7/42 Moo 1
Soi Sakaengam 17, Rama II Rd
Samaedum
Bangkhuntien
Bangkok 10150
Tel - 02 894 9486
- 02 894 9487
Fax - 02 8928866
email - inter@interteca.com
- wiroj@interteca.com

USA

Kinetrol USA Inc
1200 Placid Ave
Suite 700
Plano
Texas 75074
Tel - 972 447 9443
Fax - 972 447 9720
email - sales@kinetrolusa.com

KINETROL

Kinetrol Ltd, Trading Estate, Farnham, Surrey, GU9 9NU, England
Telephone: +44 (0)1252 733838 Fax: +44 (0)1252 713042
www.kinetrol.com e-mail: sales@kinetrol.com

Distributed by: